

**BORLETTI 835/30** Superautomatik  
Freiarm

Nähmaschinen

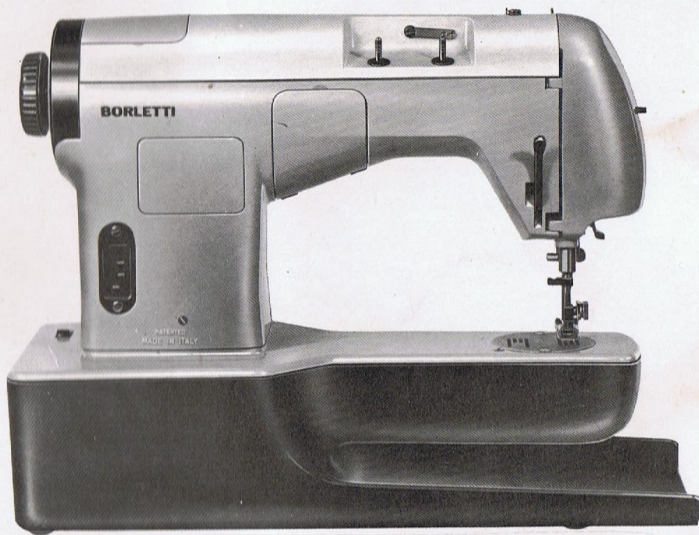

Gebrauchsanweisungen

**BORLETTI 835/30** Superautomatik  
Freiarm

Nähmaschinen

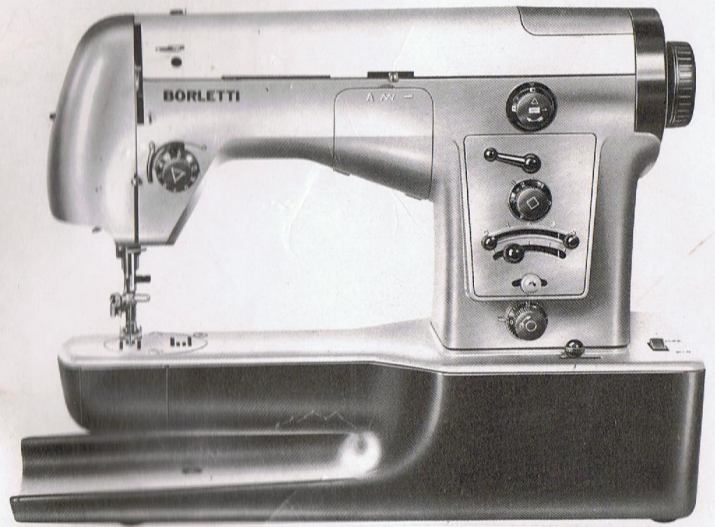

Gebrauchsanweisungen



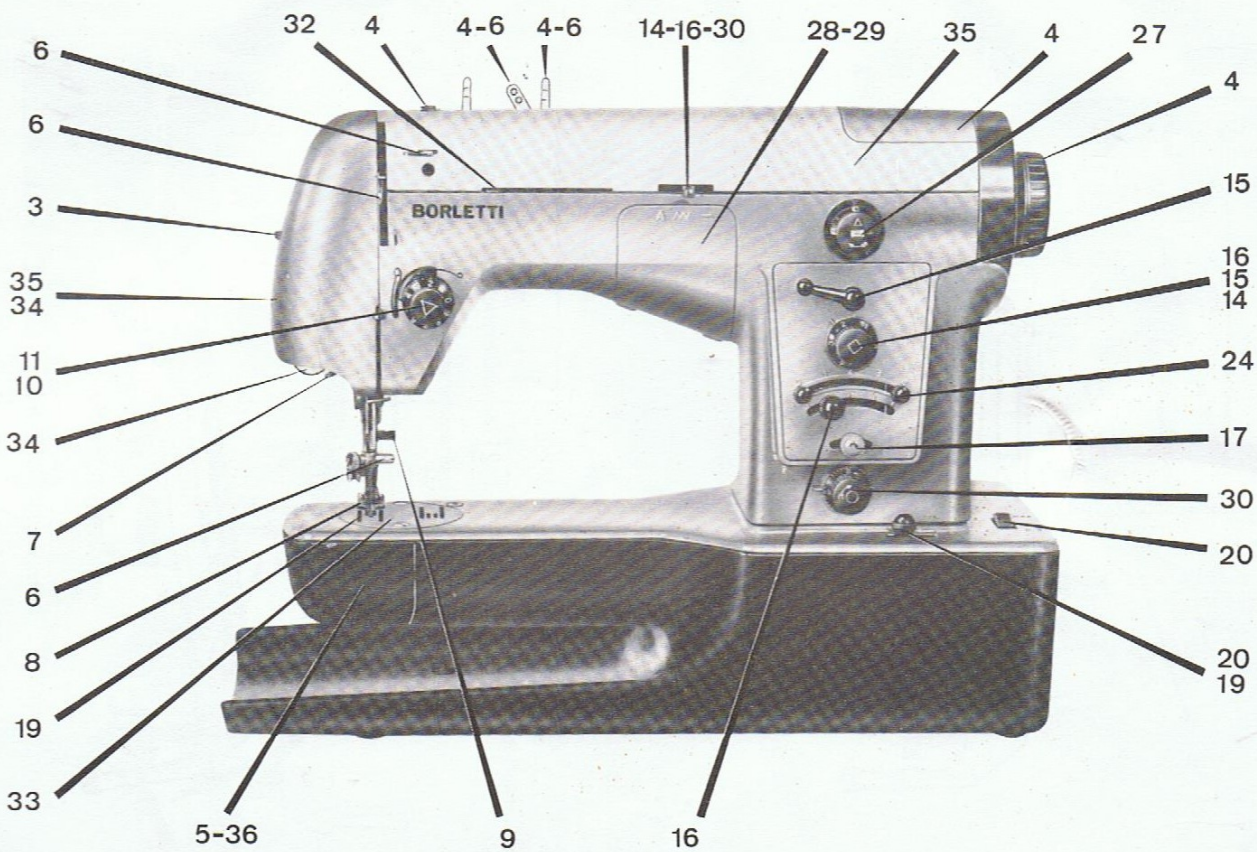

**BORLETTI**



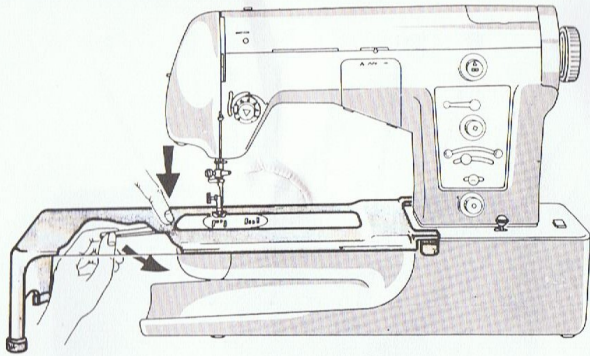

1 Anstiehetisch befestigen

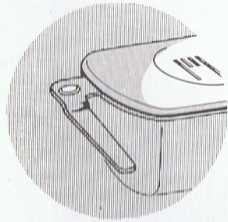

2 Anstiehetisch abnehmen

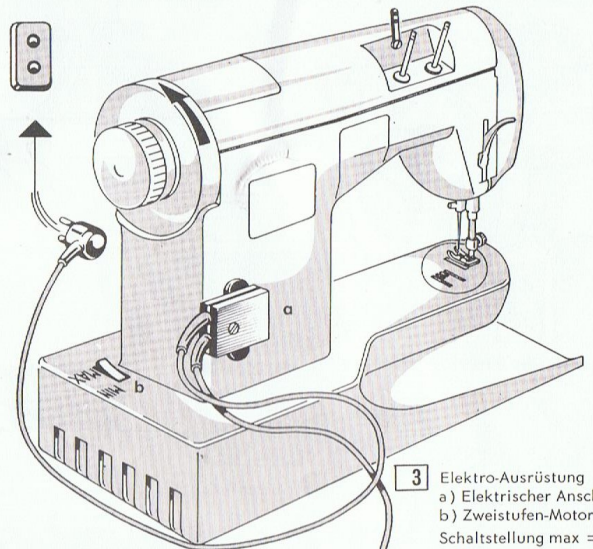
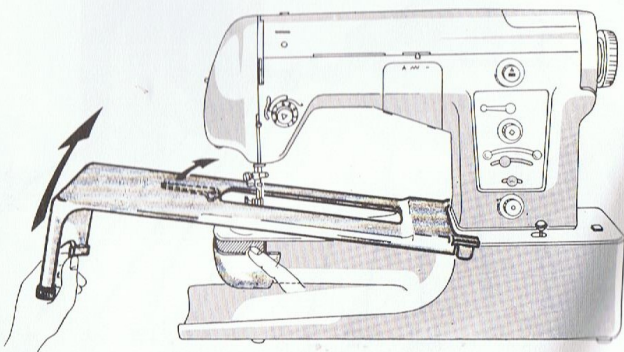

3 Elektro-Ausrüstung  
a) Elektrischer Anschluss  
b) Zweistufen-Motor  
Schaltstellung max = normale Geschwindigkeit  
Schaltstellung min = reduzierte Geschwindigkeit

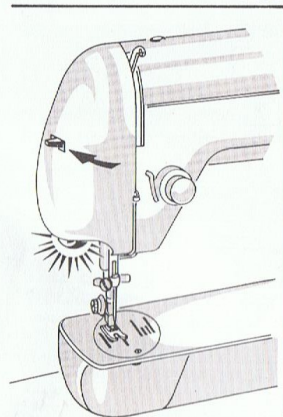

4 Einschalten des Nählichtes

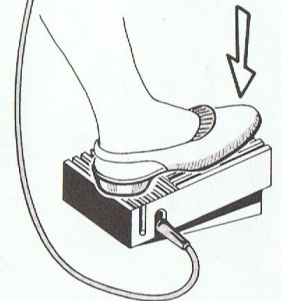

5 Fussanlasser zur stufenlosen  
Regelung der Nähgeschwindigkeit



6 Auslösen des Handrades (zum Spulen)

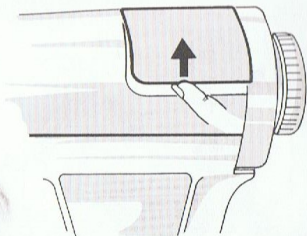

7 Öffnen des Spulerdeckels

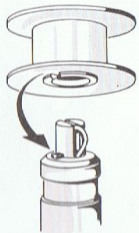

9 Aufsetzen der Spule

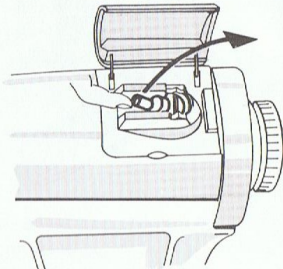

8 Spuler hochkippen (spulbereit)

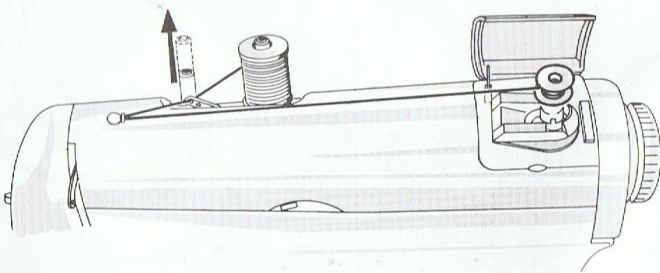

10 Fadenführung zum Spulen

11 Einsetzen der Spule in die Spulenkapsel



11a Faden unter die Spannfeder und den Fadenführungshaken führen

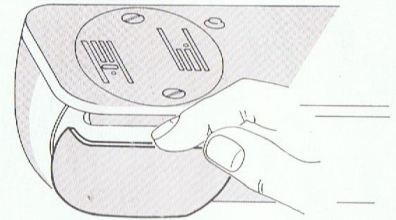

12 Öffnen der Greiferabdeckplatte

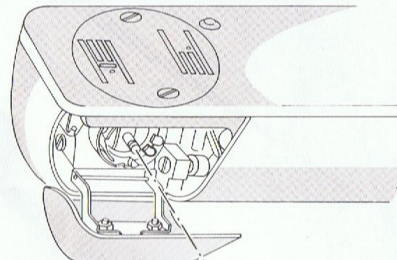

13 Spulenkapsel einsetzen (Herausnehmen entgegengesetzt)

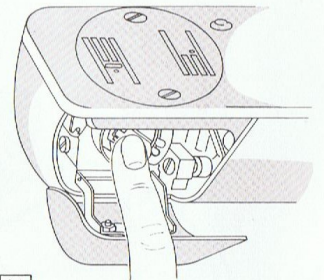

14 Spulenkapsel eingesetzt und gesichert



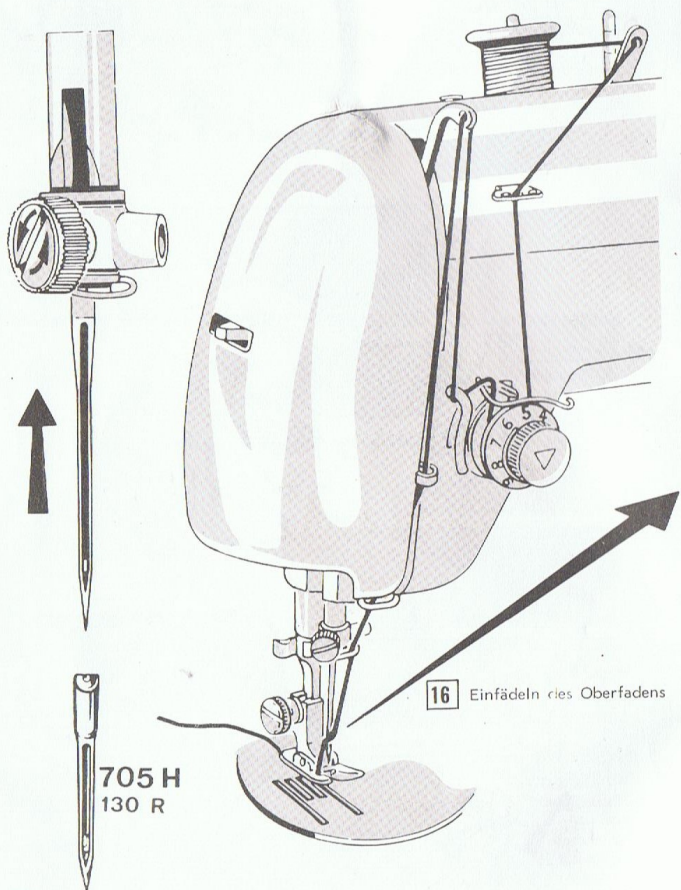

15 Einsetzen der Nadel

16 Einfädeln des Oberfadens

17 Eingebauter Nadeleinfädler

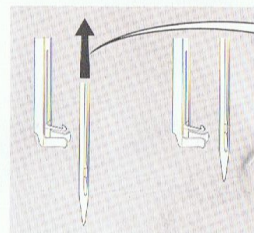

17a Nadel in die höchste Stellung bringen

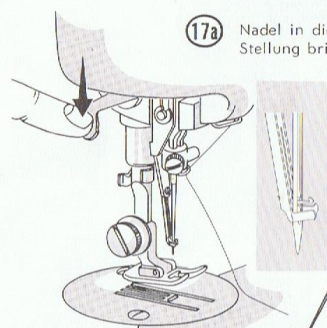

17b Hebel drücken bis Haken in Nadelöse eindringt

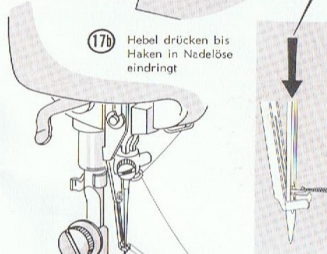

17c Faden in Haken einlegen

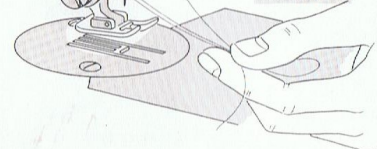

17d Hebel in die ursprüngliche Stellung bringen

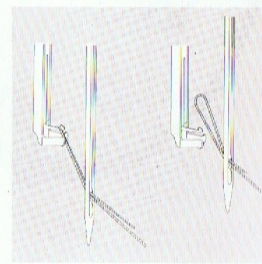
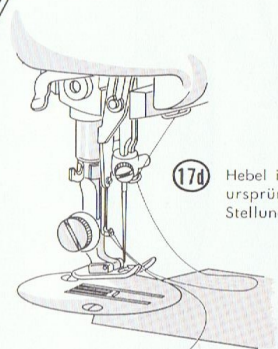

18 Stoffdruck des Nähfusses

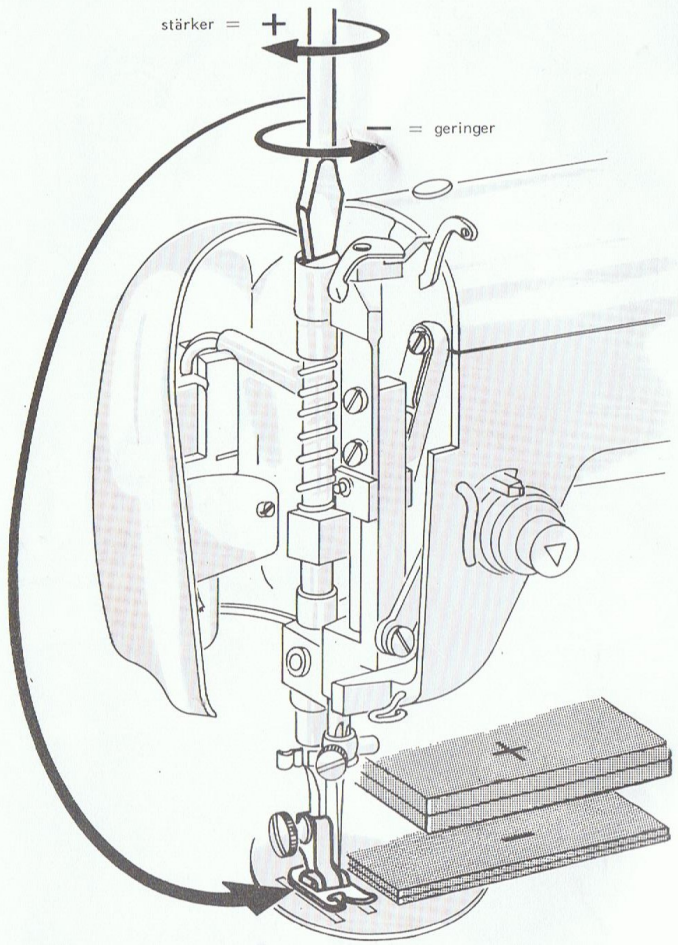

19 Beginn des Nähens (Hochholen des Unterfadens)

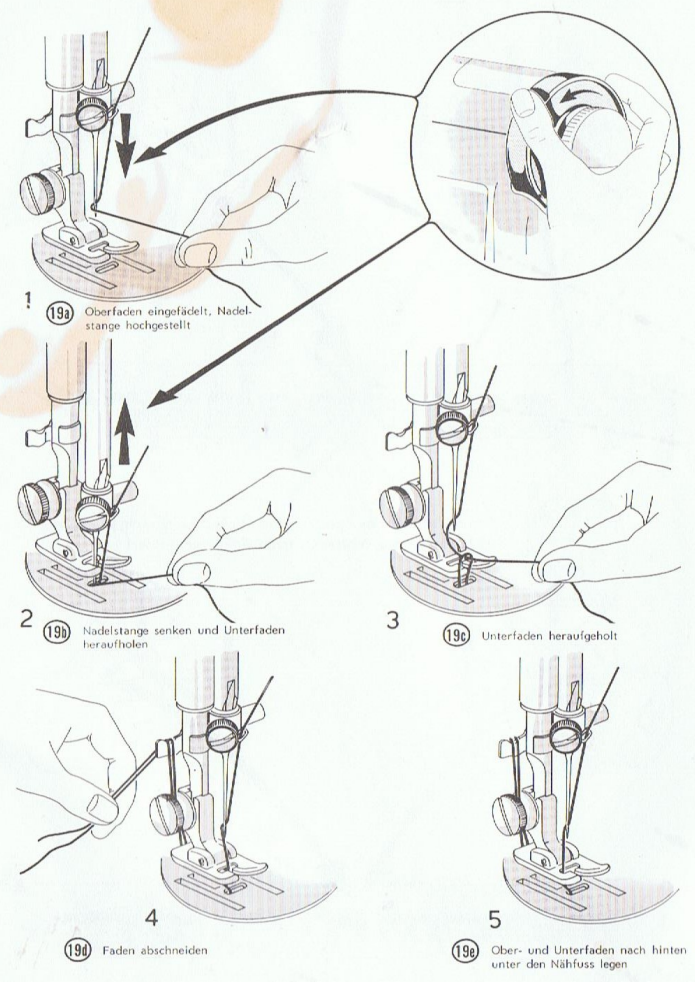



20 Fadenspannung (oben)

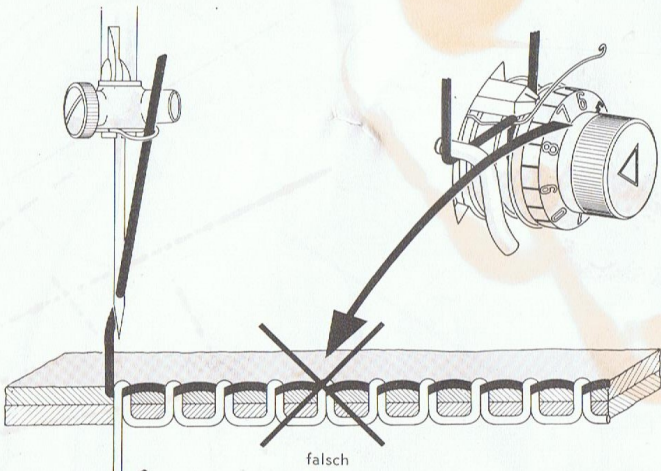

Durch Drehen des Fadenspannknopfes nach rechts wird die Fadenspannung verstärkt, nach links vermindert

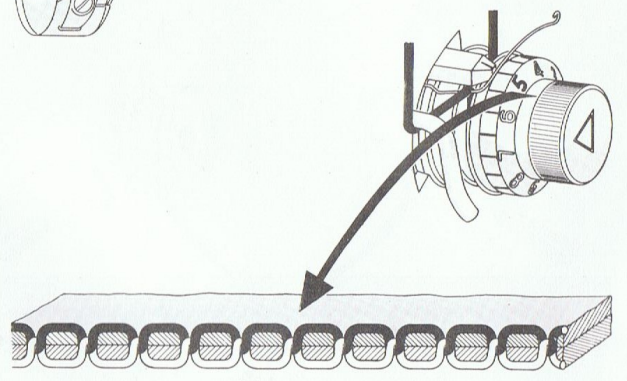
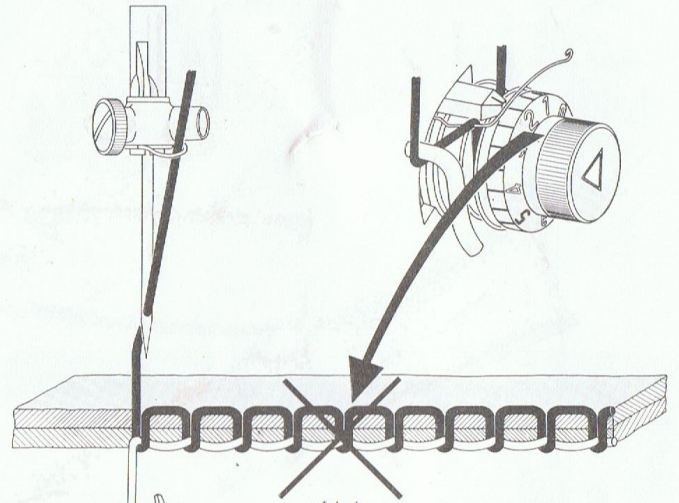
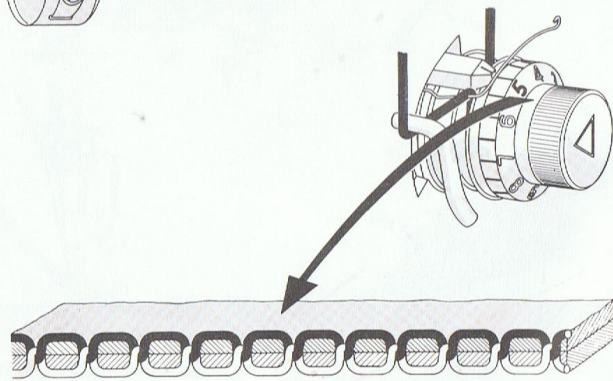

21 Fadenspannung (unten)

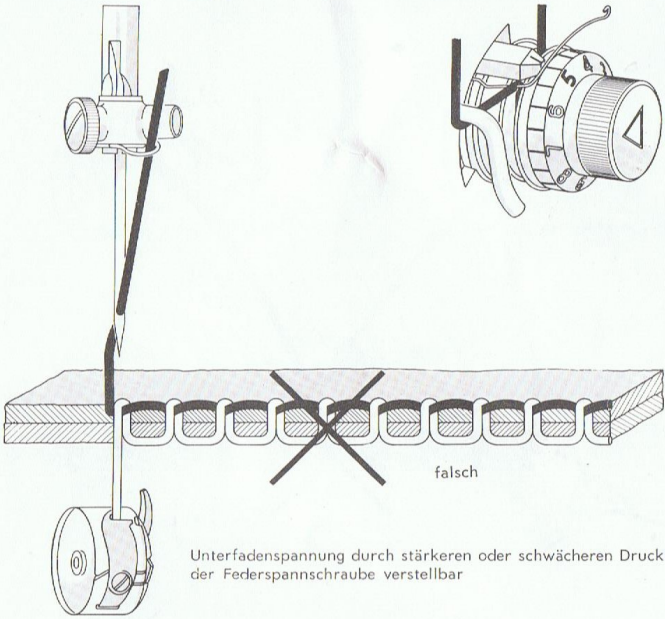

Unterfadenspannung durch stärkeren oder schwächeren Druck der Federspannschraube verstellbar

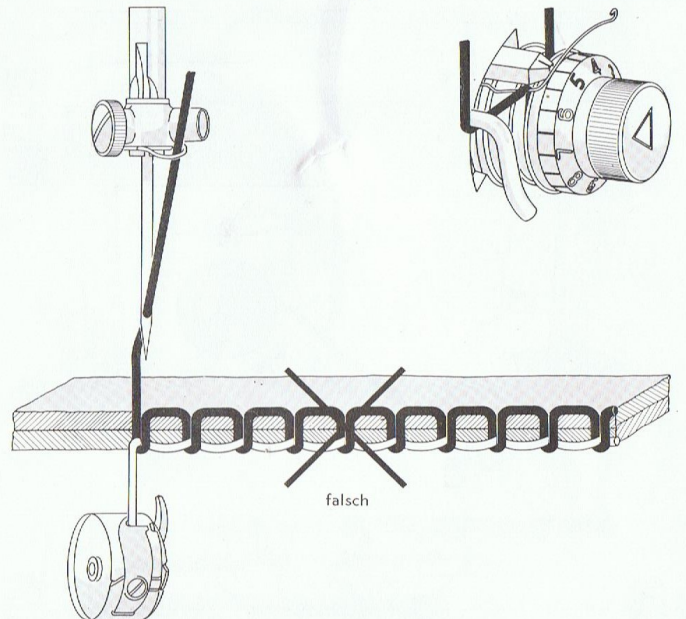



22 Einstellen der Stichtlänge

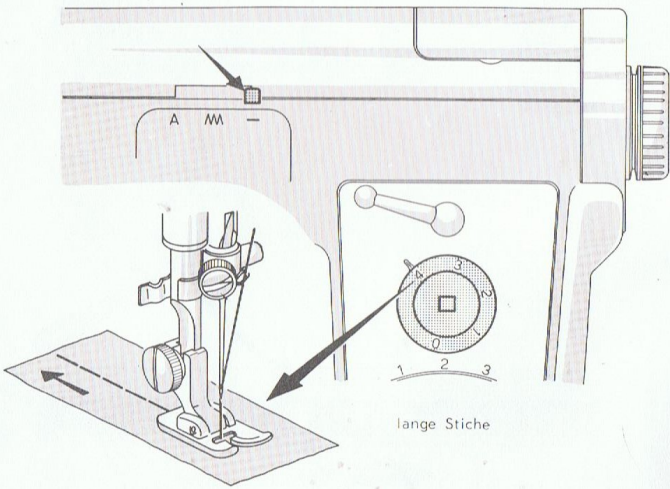
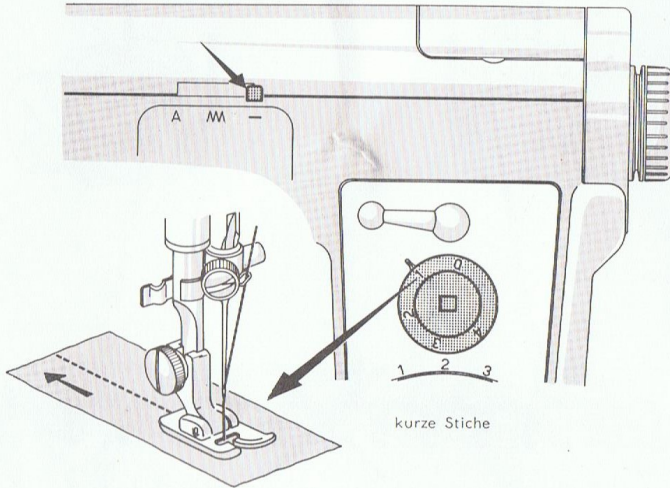

23 Rückwärtsnähen

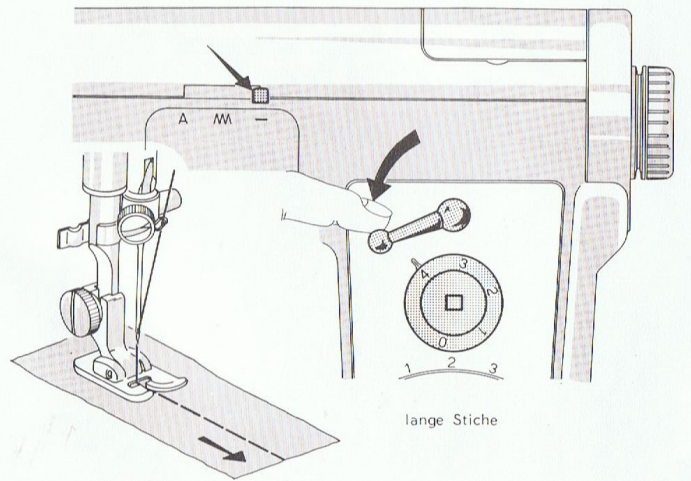
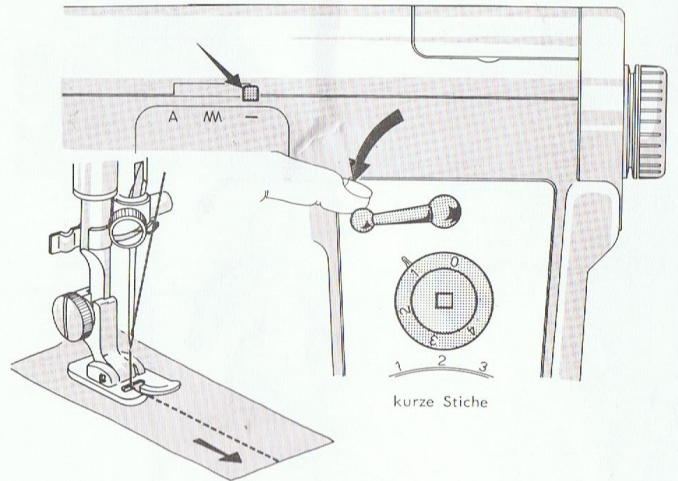

24 Einstellung der Stichbreite

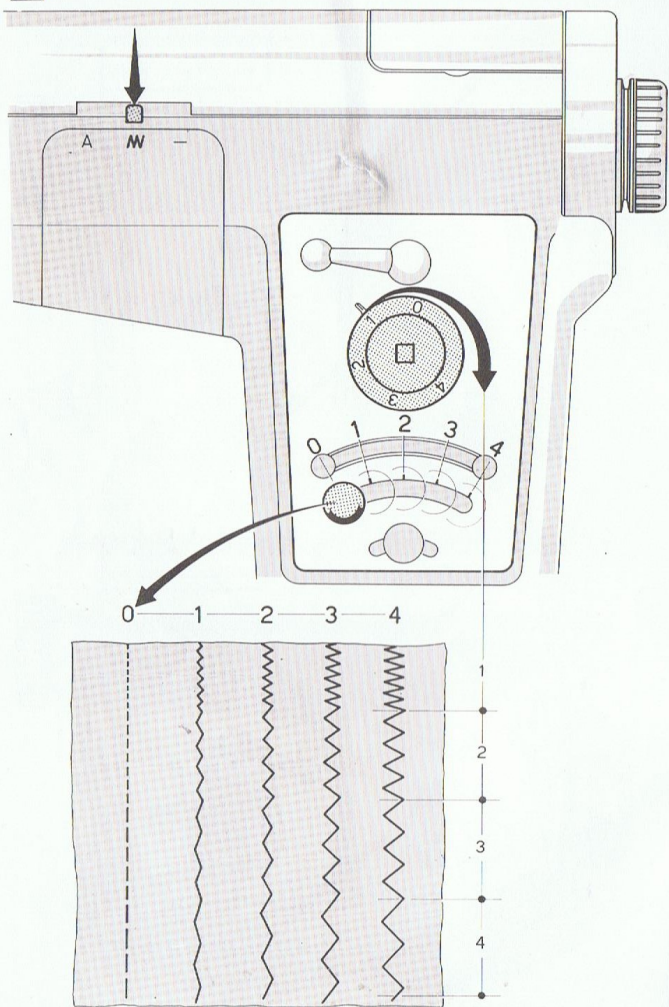

25 Stichlage

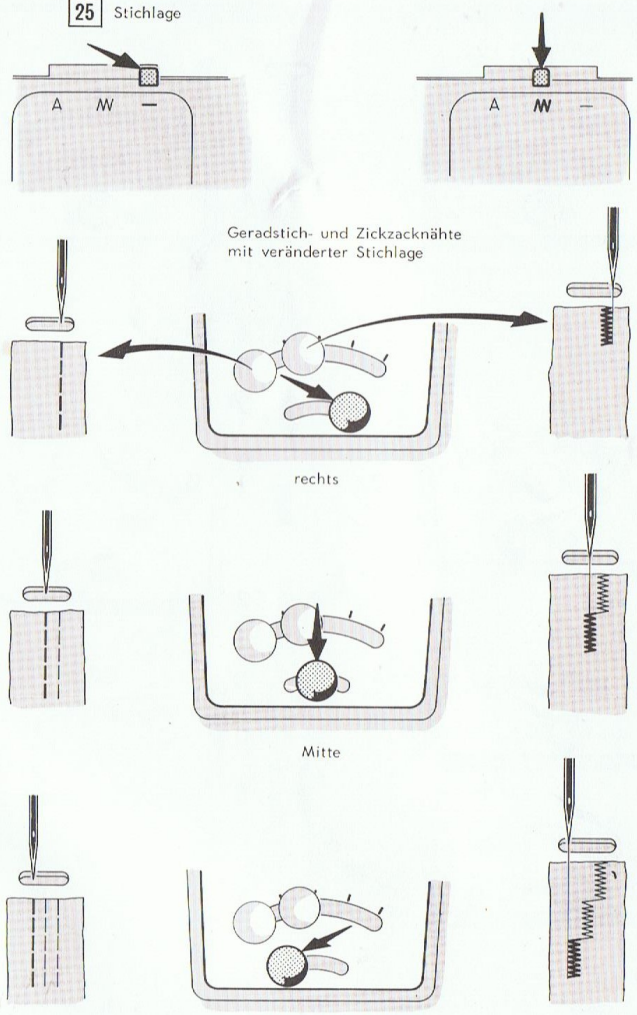





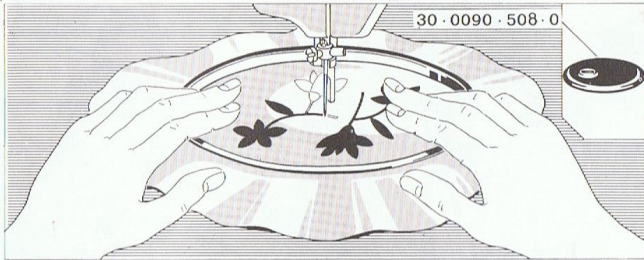
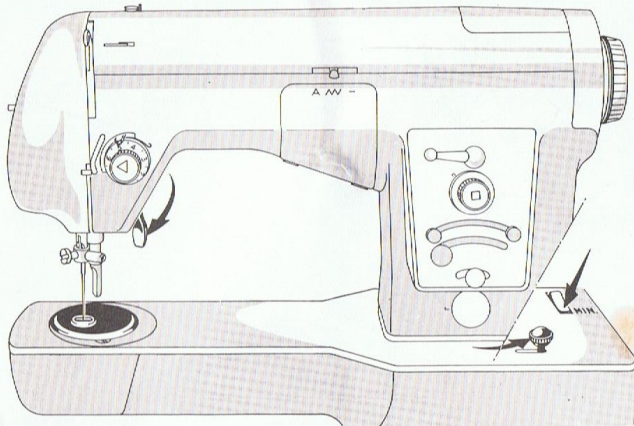

30 · 0090 · 508 · 0

28 Sticken (Transporteur unten)

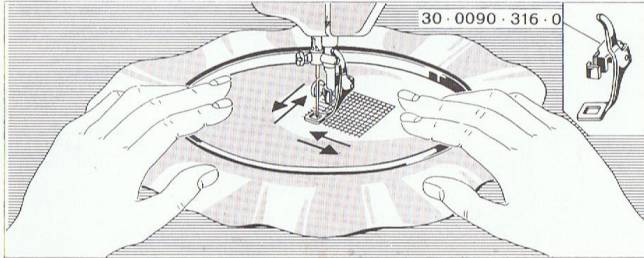

30 · 0090 · 316 · 0

29 Stopfen (Transporteur unten)

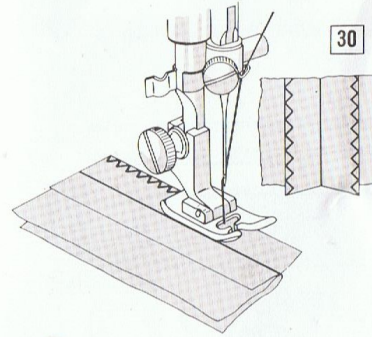

30 Nähte versäubern

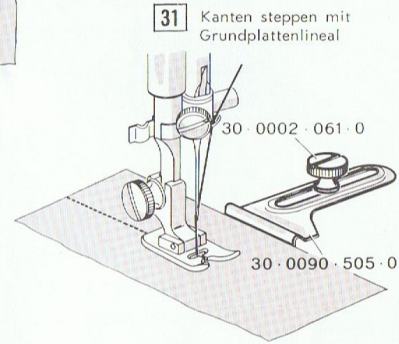

31 Kanten steppen mit Grundplattenlineal

30 · 0002 · 061 · 0

30 · 0090 · 505 · 0

32 Reissverschluss einnähen

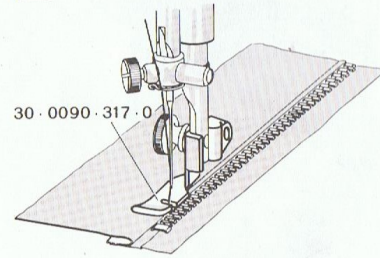

30 · 0090 · 317 · 0

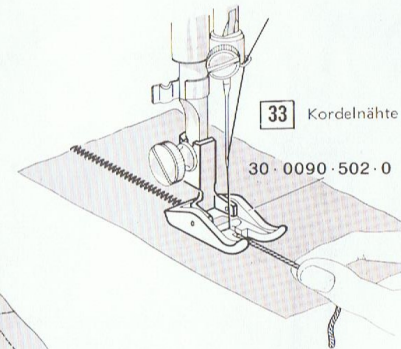

33 Kordelnähte

30 · 0090 · 502 · 0

34 Wattieren (mit Lineal)

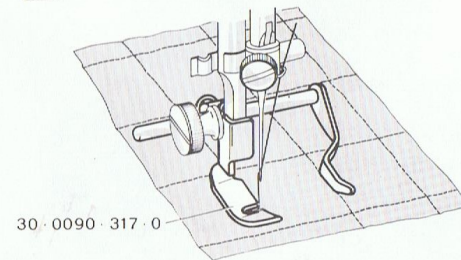

30 · 0090 · 317 · 0



**35** Nähen mit Zwillingenadeln (für Biesen- oder Parallel-Nähte mit Geradstich sowie für Zickzack- und Ziersticharbeiten)

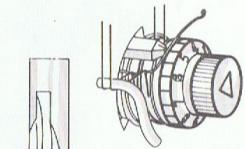
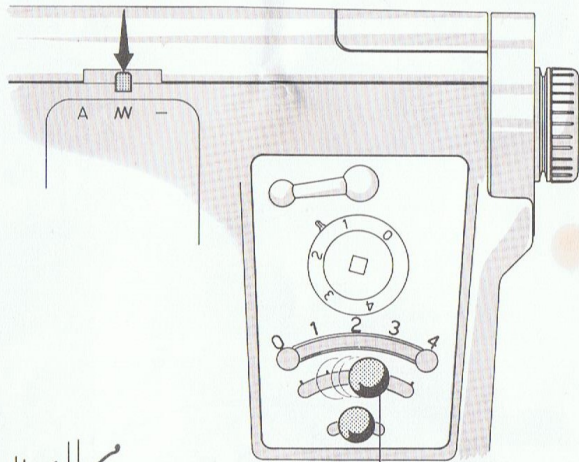

höchstmögliche Zickzack-Überstichbreite

1,3 1,8 2,2 2,5 2,5  
3 2,5 2 1,8 1,6 mm.

Nadelabstand (NE)

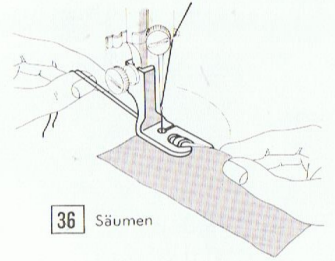

**36** Säumen

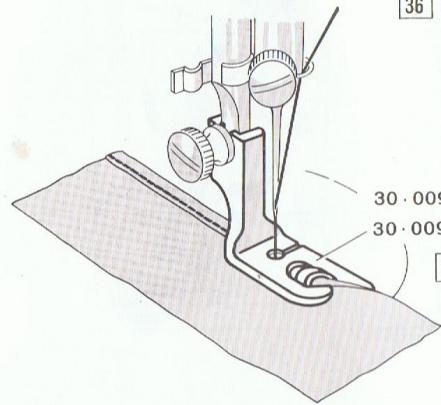

30 · 0090 · 320 · 0  
30 · 0090 · 312 · 0

**37** Kappen

**38** Rollsaum

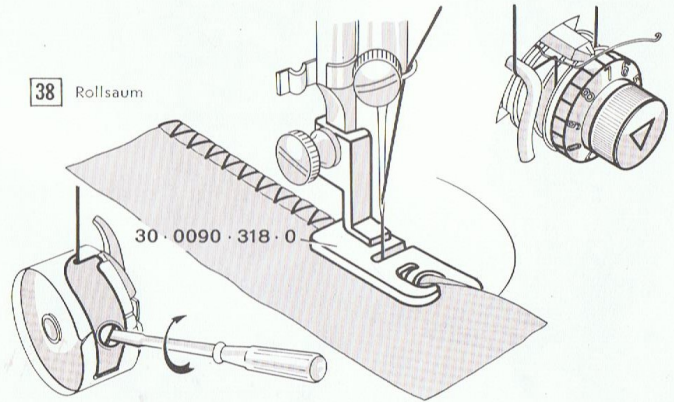

30 · 0090 · 318 · 0

**39** Knöpfe annähen

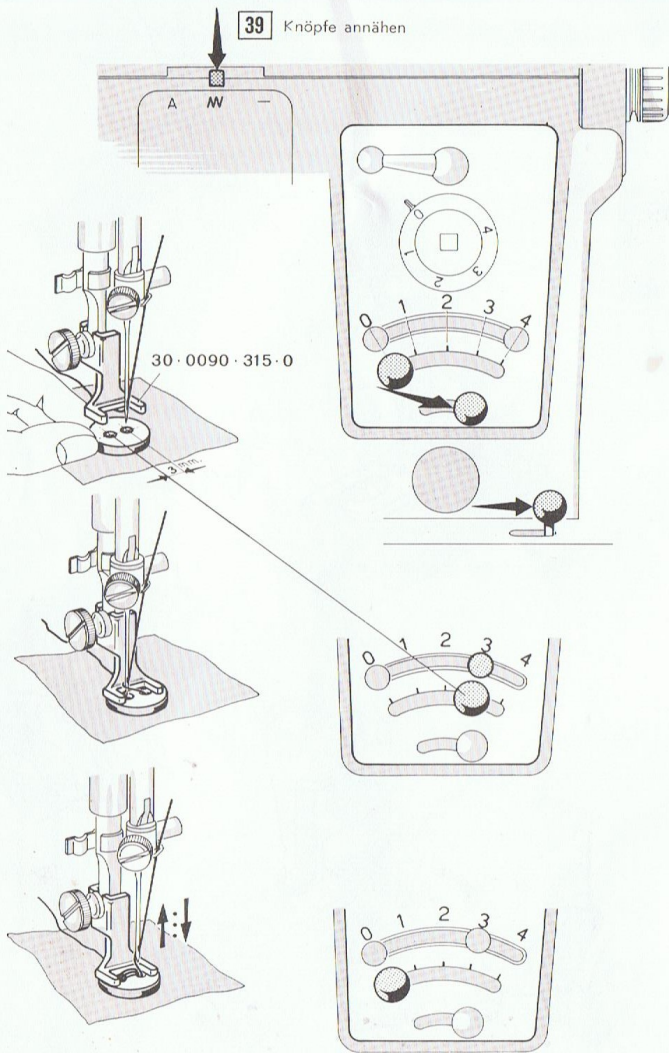

24

**40** Blindsticharbeiten (mit Blindstichkantenfeder)

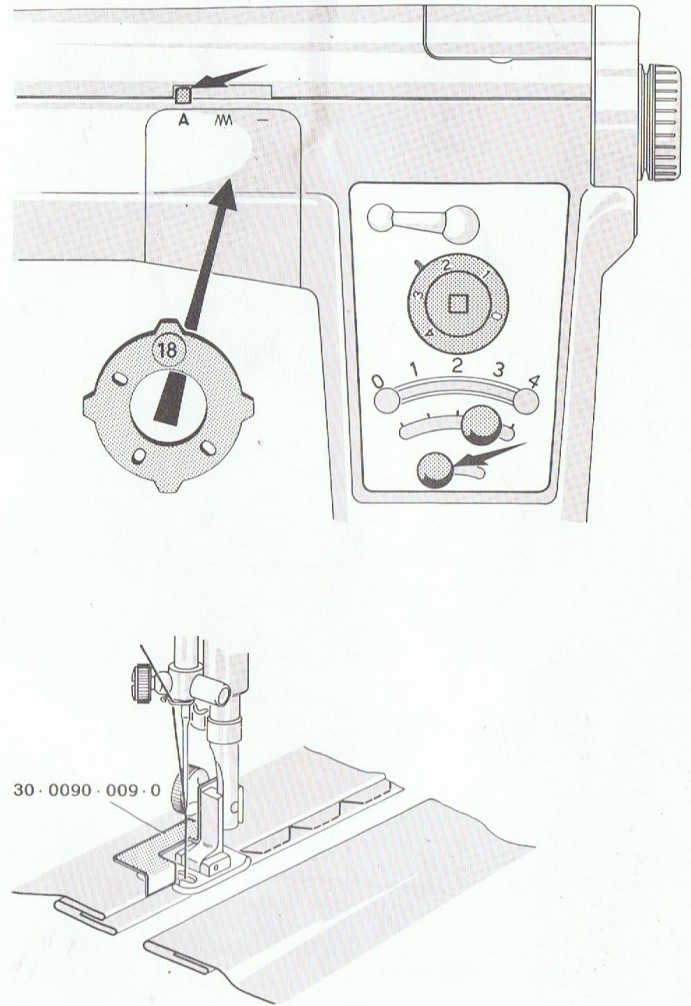

25



41 Knopflöcher nähen

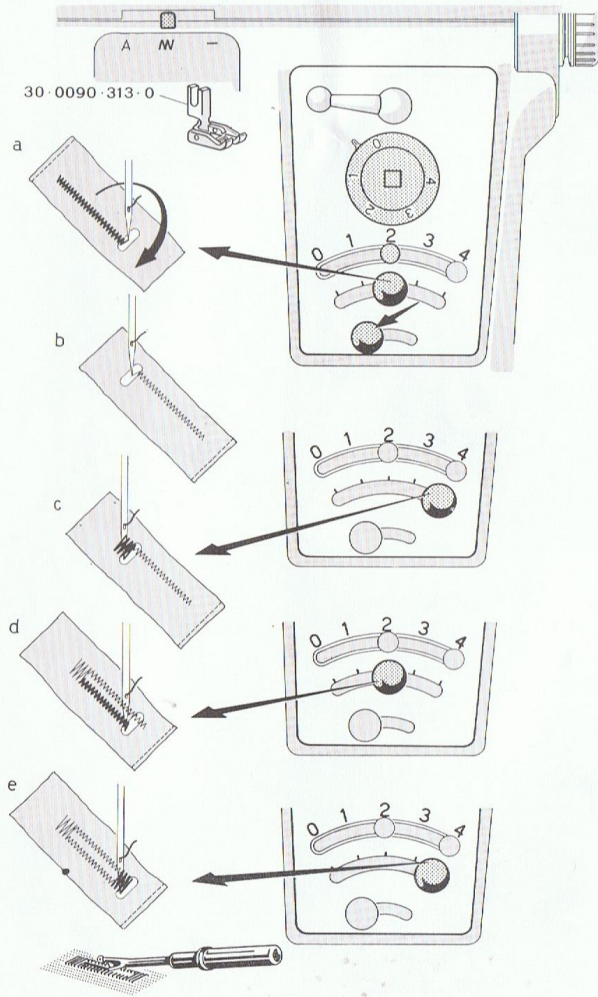

42 Knopflöcher nähen (mit eingebauter Knopflochautomatik)

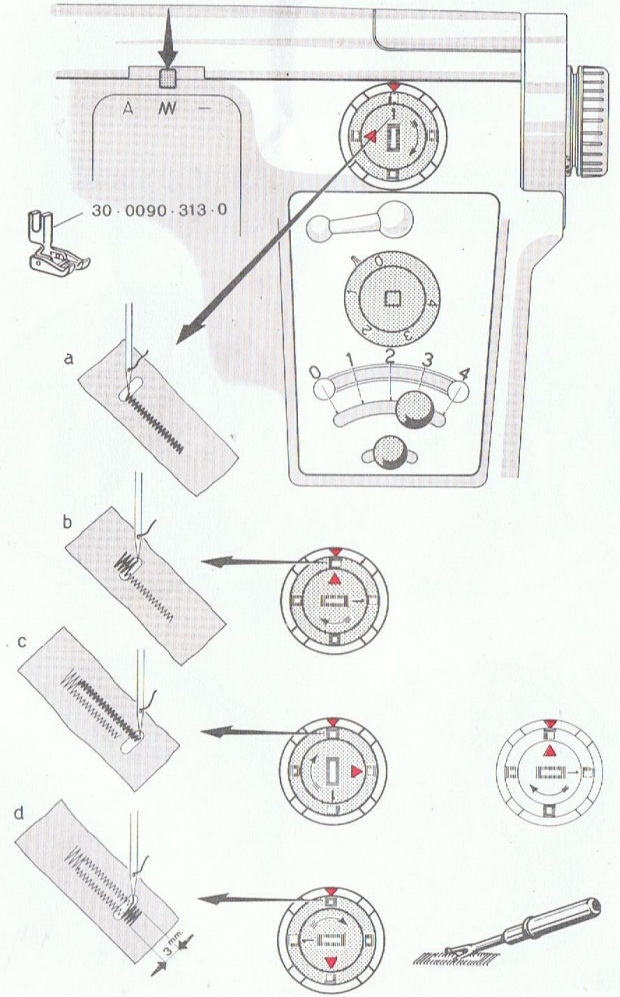

43 Mit der Automatik ausgeführte  
Ziersticharbeiten

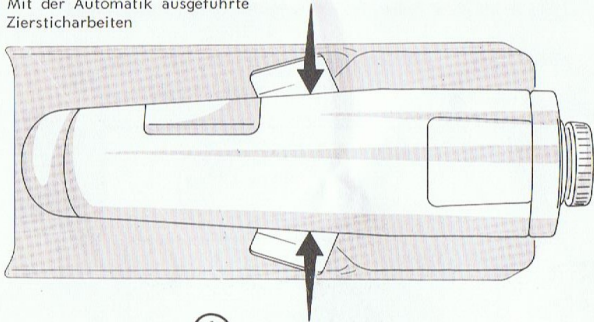

1 Einsetzen der Kurven

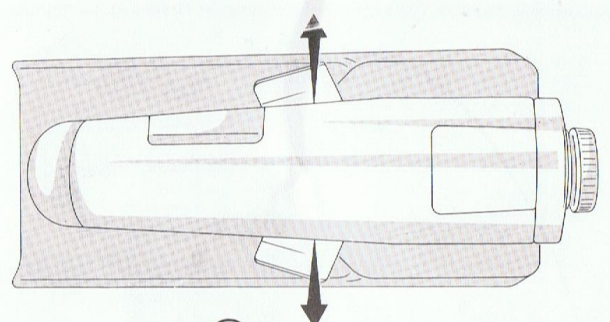
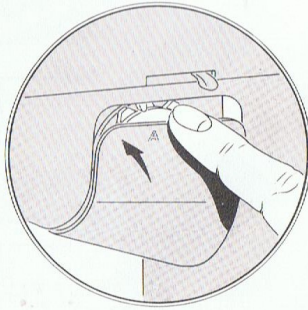
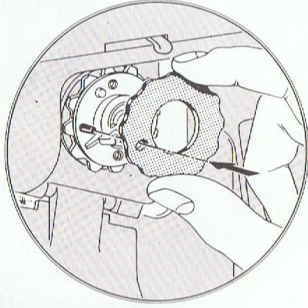
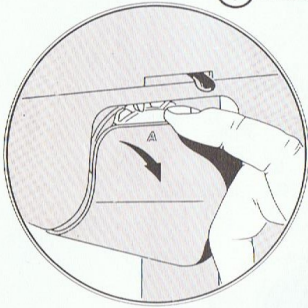

2 Herausnehmen der  
Kurven

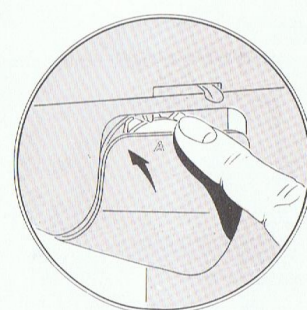
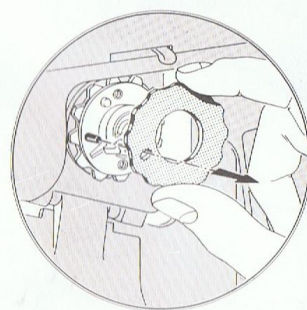
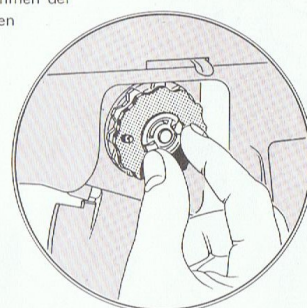
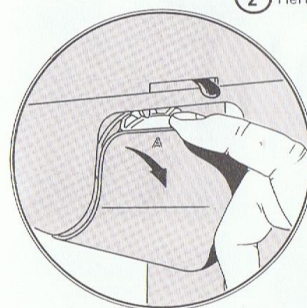



43 Mit der Automatik ausgeführte Ziersticharbeiten

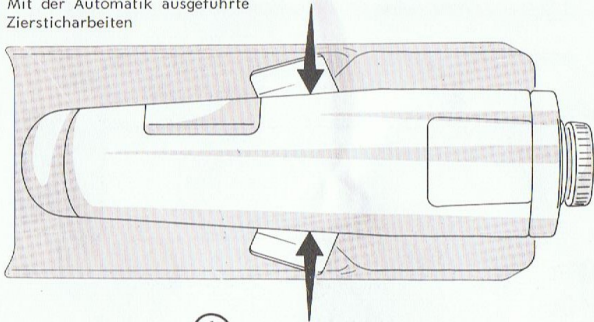

1 Einsetzen der Kurven

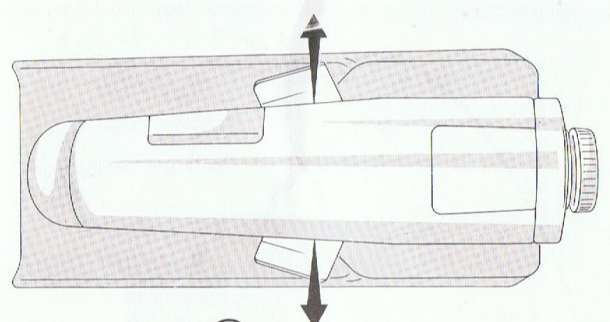
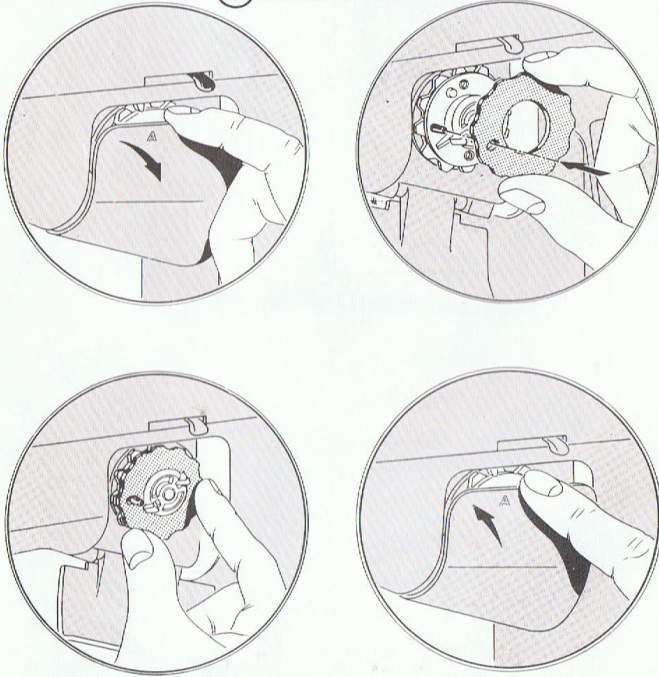

2 Herausnehmen der Kurven

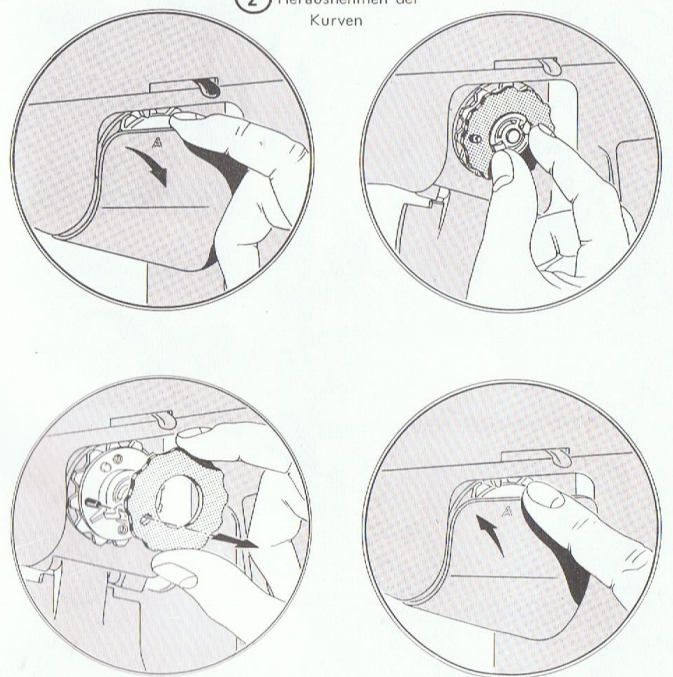

3 Superautomatische Ziernähte (automatische Betätigung der Nadel und des Transporteurs)

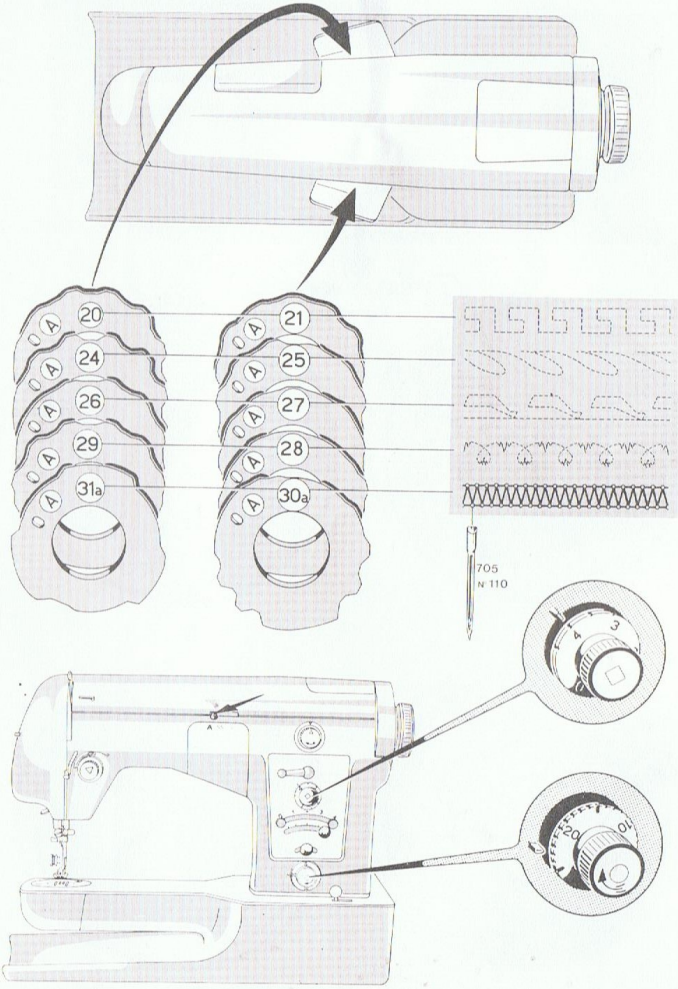

4 Automatische Ziernähte (automatische Betätigung der Nadel)

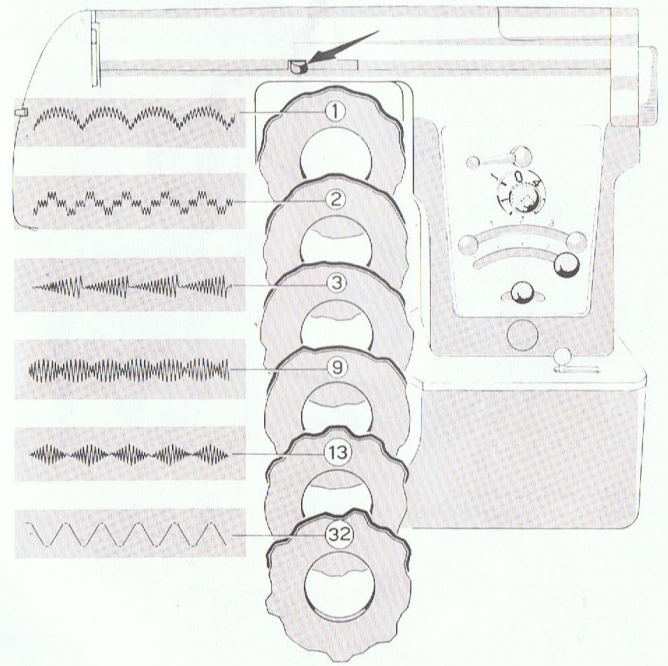



44 Eingebauter Hefter (Ausführung des Heftstiches)

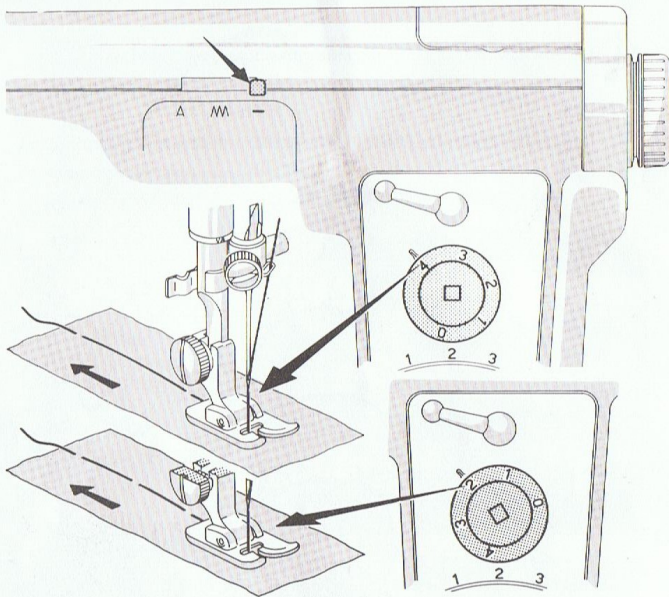

Einfädeln des Oberfadens  
(Obergarn Nr. 50-60 verwenden, Motoreinstellung « MIN »)

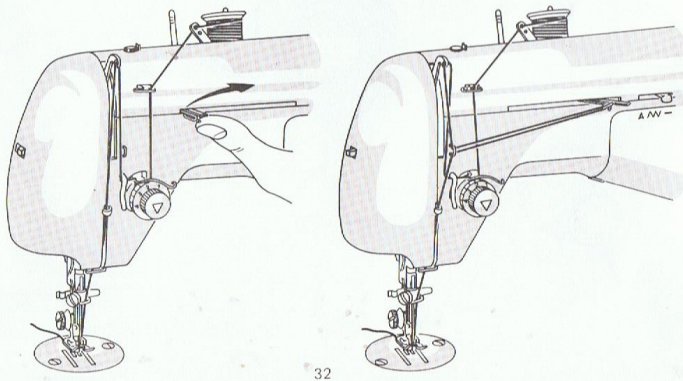

32

45 Drehbare Spezial-Stichplatte für Geradstich- und Zickzacknähte

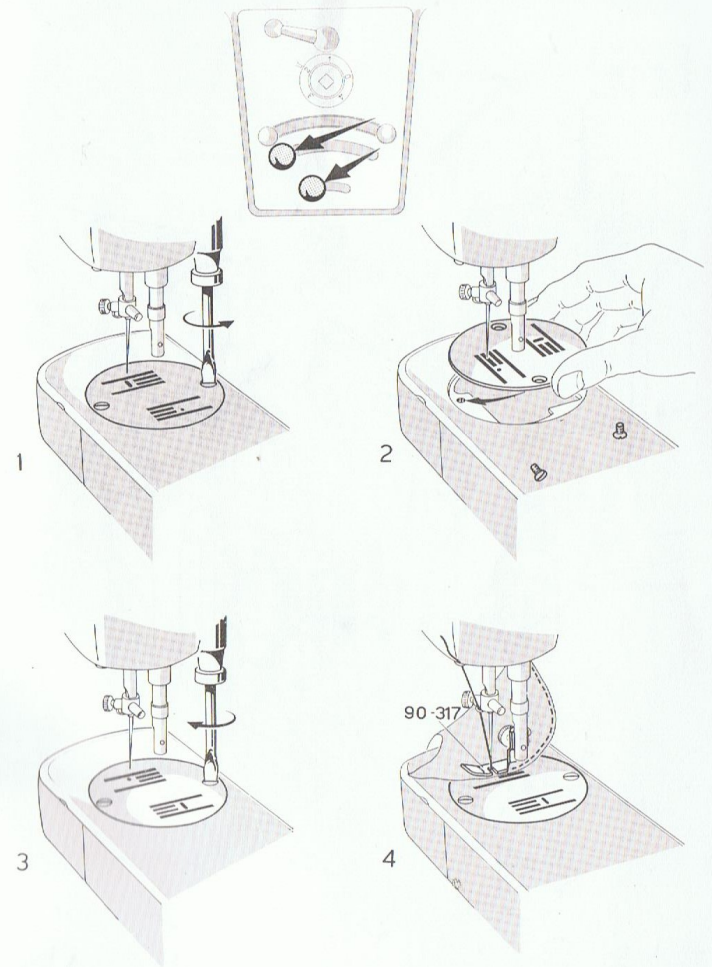

33

46 Einsetzen der Glühbirne

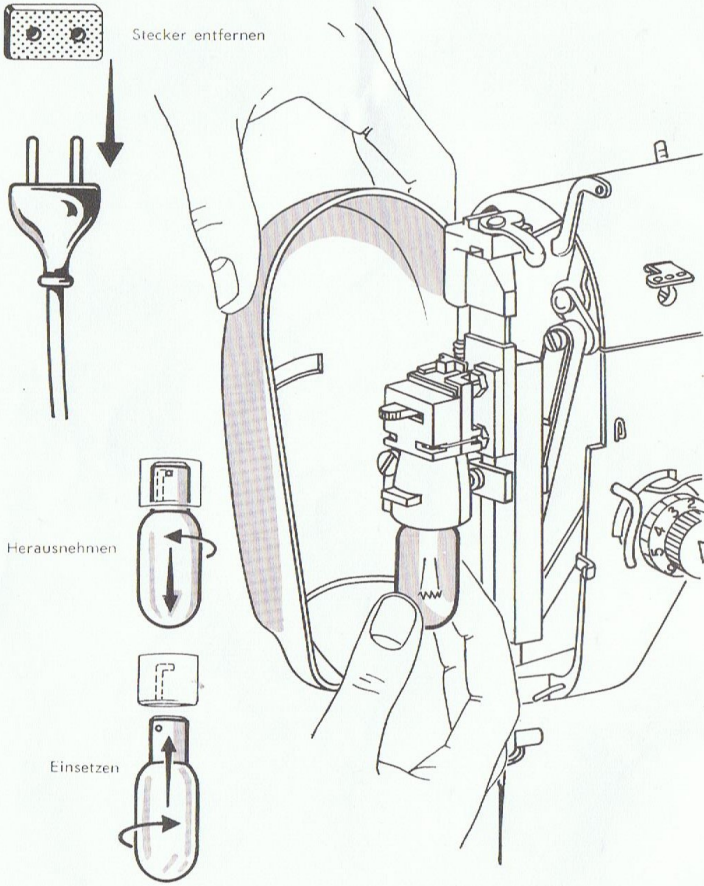

47 Armdeckel abnehmen

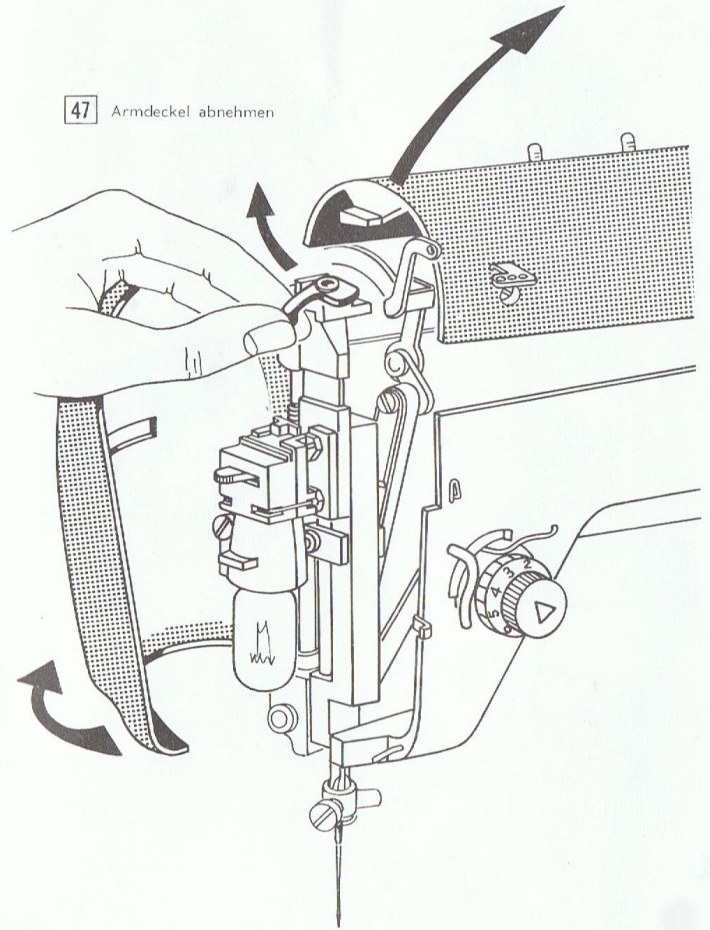



48 Reinigung und Schmierung

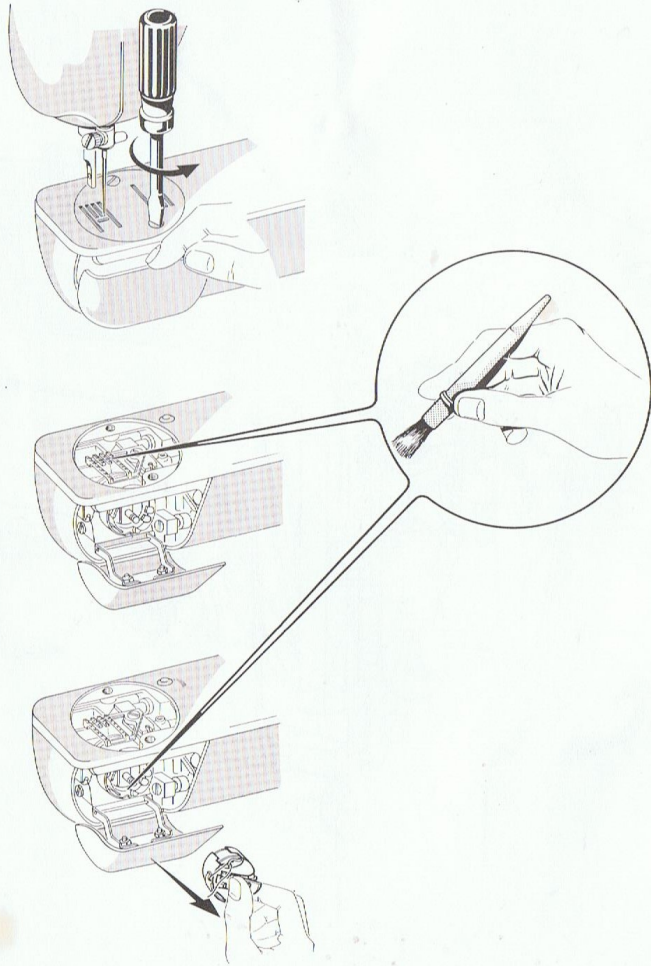

1 Schmierstellen

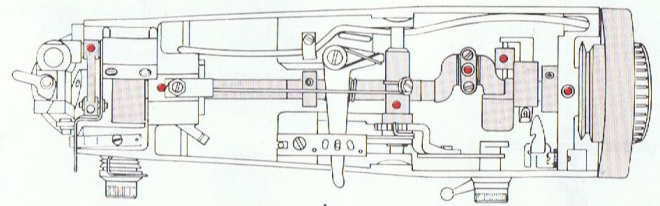
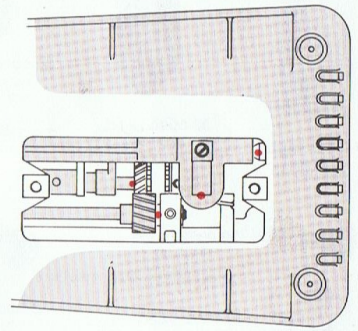
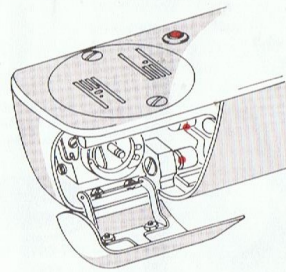
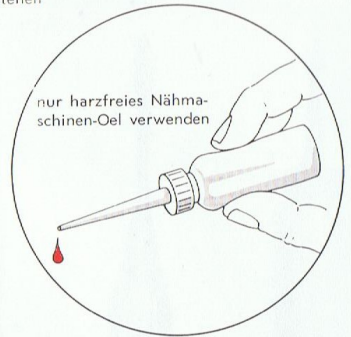
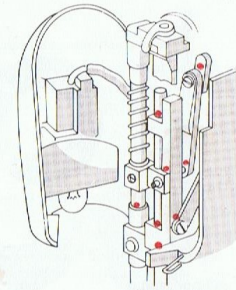



INHALTSVERZEICHNIS

Abb. - Nr.		Seite
1	Anschiebetisch befestigen	2
2	Anschiebetisch abnehmen	2
3	Elektro-Ausrüstung (Anschluss)	3
4	Einschalten des Nählichtes	3
5	Fussanlasser	3
6	Auslösen des Handrades	4
7	Spulendeckel öffnen	4
8	Spuler hochkippen	4
9	Aufsetzen der Spule	4
10	Spulerradführung	4
11	Einsetzen der Spule	5
12	Öffnen der Greiferabdeckplatte	5
13	Spulenkapsel einsetzen	5
14	Spulenkapsel eingesetzt	5
15	Einsetzen der Nadel	6
16	Einfädeln des Oberfadens	6
17	Eingebauter Nadeleinfädler	7
18	Stoffdruck des Nähfusses	8
19	Beginn des Nähens (Hochholen des Unterfadens)	9
20	Fadenspannung (oben)	10/11
21	Fadenspannung (unten)	12/13
22	Einstellen der Stichlänge	14
23	Rückwärts nähen	15
24	Einstellen der Stichbreite	16
25	Stichlage	17
26	Zickzacknähte mit veränderter Stichlage und Stichbreite	18
27	Transporteur-Einstellung	19
28	Sticken	20
29	Stopfen	20
30	Nähte versüßern	21
31	Grundplattenlineal	21
32	Reissverschluss einnähen	21
33	Kordelnähte	21
34	Wattieren (mit Lineal)	21
35	Nähen mit Zwillingsschneidern	22
36	Säumen	23
37	Kappen	23
38	Rollsaum	23
39	Knöpfe annähen	24
40	Blindsticharbeiten	25



41	Knopflöcher nähen . . . . .	26
42	Knopflöcher nähen (mit eingebauter Automatik) . . . . .	27
43	Mit der Automatik ausgeführte Ziersticharbeiten . . . . .	28/31
44	Hefstich . . . . .	32
45	Drehbare Spezial-Stichplatte . . . . .	33
46	Einsetzen der Glühbirne . . . . .	34
47	Armdeckel abnehmen . . . . .	35
48	Reinigung und Schmierung . . . . .	36/37
49	Zubehör . . . . .	38

**BORLETTI** ENCICLOPEDIA  
DEL RICAMO

ENZYKLOPAEDIE  
DER  
AUTOMATISCHEN  
STICKMUSTER

ENCYCLOPÉDIE  
DE LA  
BRODERIE  
AUTOMATIQUE

ENCICLOPEDIA  
DEL  
BORDADO  
AUTOMATICO

KORUKUVIOINNIN  
JA  
HYÖTYOMPELEIDEN  
HAKEMISTO

ENCYCLOPAEDIA  
OF THE  
AUTOMATIC  
EMBROIDERY  
PATTERNS

ENCYCLOPÉDIE  
VOOR  
AUTOMATISCH  
BORDUREN EN  
PRACTISCHE STEKEN

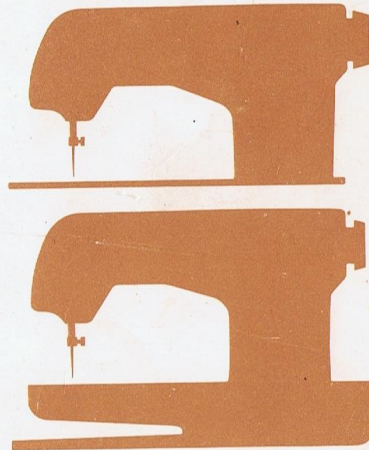



### REGOLAZIONE DEI COMANDI E MONTAGGIO DELLE CAMME PER IL RICAMO AUTOMATICO

Infinite sono le varietà dei ricami eseguibili automaticamente con la nostra Superautomatica. Nelle pagine seguenti ci siamo perciò limitati ad illustrare solo alcuni dei ricami possibili, ma vi accorgete nel familiarizzarvi con la nostra macchina, che migliaia di altri, scaturiti dalla vostra fantasia, saranno altrettanto facili ed attraenti da eseguire.

**NOTA:** Le indicazioni date per il bottone « V » sono orientative. Per una esatta riproduzione del disegno illustrato sarà a volte necessario ruotare il bottone di alcuni gradi.

**NOTA:** L'Enciclopedia contiene lavori ottenibili sia con le camme facenti parte del normale corredo della macchina, che con quelle ottenibili a pagamento.

LITO-TIPO MORO - 36022 CASSOLA

### Automatic Embroidery

In the following pages we have illustrated only a few of the hundreds of thousands of beautiful designs that your Super Deluxe Automatic will perform for you. For your information we have illustrated also designs carried out with cams that are available as extra attachments and are not supplied normally with the machine.

**Note:** The readings indicated for knob « V » are only approximate. For the exact reproduction of the drawing, turn knob left or right slowly until the correct position is found.

### Regulierung der Startknöpfe und Montieren der Zierstickkurven für automatisches Sticken

Unzählige sind die Stickmuster die man automatisch mit unserer « Superautomatic » ausführen kann. In nachfolgenden Seiten haben wir uns beschränkt nur einige der ausführbaren Stickmuster zu zeigen, aber Sie werden, sobald Sie sich mit unserer Nähmaschine etwas eingearbeitet haben werden, merken, dass noch tausende von Mustern, aus Ihrer Phantasie stammend, ebenso schön und leicht erhältlich sind.

**Anmerkung:** Die Anweisungen für den Knopf « V » sind nur zur Orientierung gegeben; für eine genaue Wiedergabe der gezeigten Stickmuster, wird es manchmal noetig sein den Knopf um einige Grade zu drehen.

**Anmerkung:** Die Enzyklopädie enthält Arbeiten welche mit den Kurven die der Maschine mitgegeben werden erhältlich sind, wie auch mit jenen die separat verkauft werden.

### Réglage des commandes et montage des cammes pour la broderie automatique

La variété des broderies qu'on peut exécuter automatiquement avec notre « Superautomatic » est infinie. Dans les pages qui suivent nous sommes limités à présenter quelques dessins possibles, mais vous vous apercevrez, en vous familiarisant avec notre machine, que des milliers d'autres, aussi jolis et aussi faciles à exécuter, peuvent naître de votre fantaisie.

**Note:** Les indications données per le bouton « V » ne sont pas absolues. Pour une reproduction parfaite des dessins proposés, il peut être parfois nécessaire de la tourner de quelques degrés.

**Note:** L'encyclopédie contient les travaux obtenus soit avec les cammes en dotation normale, soit avec les cammes que l'on peut acheter.

### Regulación de los mandos y montaje de los excentricos para el bordado automático

Infinitas son las variedades de los bordados realizables automáticamente con nuestra « Superautomática ». En las páginas que siguen enseñamos nada más que unos pocos bordados posibles, pero usted podrá darse cuenta, a medida que va familiarizándose con nuestra máquina, que millares de otros dibujos, brotados de su fantasía, pueden ser realizados fácil y agradablemente.

**Nota:** Las indicaciones referentes al botón « V » sirven para orientación. Para una exacta reproducción del dibujo, puede ser a veces preciso girar el botón de unos grados.

**Nota:** En la enciclopedia hay trabajos que se pueden realizar tanto con los excéntricos de los que la máquina está normalmente provista, cuanto con los excéntricos especiales a pago.



I

II

III

IV

V

ANTERIORE  
FRONT CAM  
ANTERIEURE  
ANTERIOR  
VORNE  
ETUKAAVAIN  
VOORSCHABLOON

POSTERIORE  
BACK CAM  
POSTERIEURE  
POSTERIOR  
RUECKWAERTS  
TAKAKAAVAIN  
ACHTERSCHABLOON

REGOLA PUNTO  
LENGTH REGULATOR  
REGLE POINT  
REGULA PUNTO  
STICHREGULIERUNG  
TIKINPITUUS  
REGELKNOP STEEKLENGTE

REGOLA AMPIEZZA  
WIDTH CONTROL  
WIDTGE CONTROL  
REGLAGE LARGEUR  
REGULA ANCHO  
WEITENKONTROLLE  
SIK-SAKIN LEVEYS  
ZIG-ZAG BREEDETE

MODIFICA TRASPORTO  
AUTOM REVERSE CONTROL  
REGLAGE TRANSPORTE  
MODIFICA TRANSPORTE  
TRANSPORTVERSTELLUNG  
SYOTTAJAN SAATO  
AUTOMATISCHE TRANSPORTVARIATIE

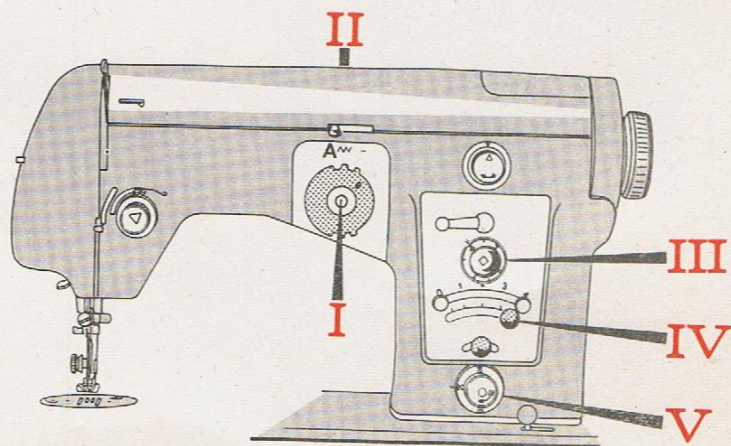
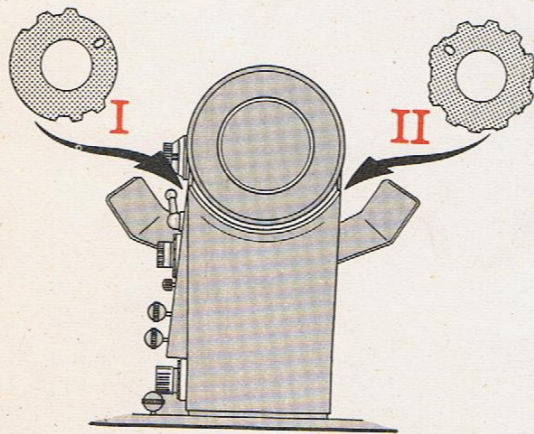

V

IV

III

II

I



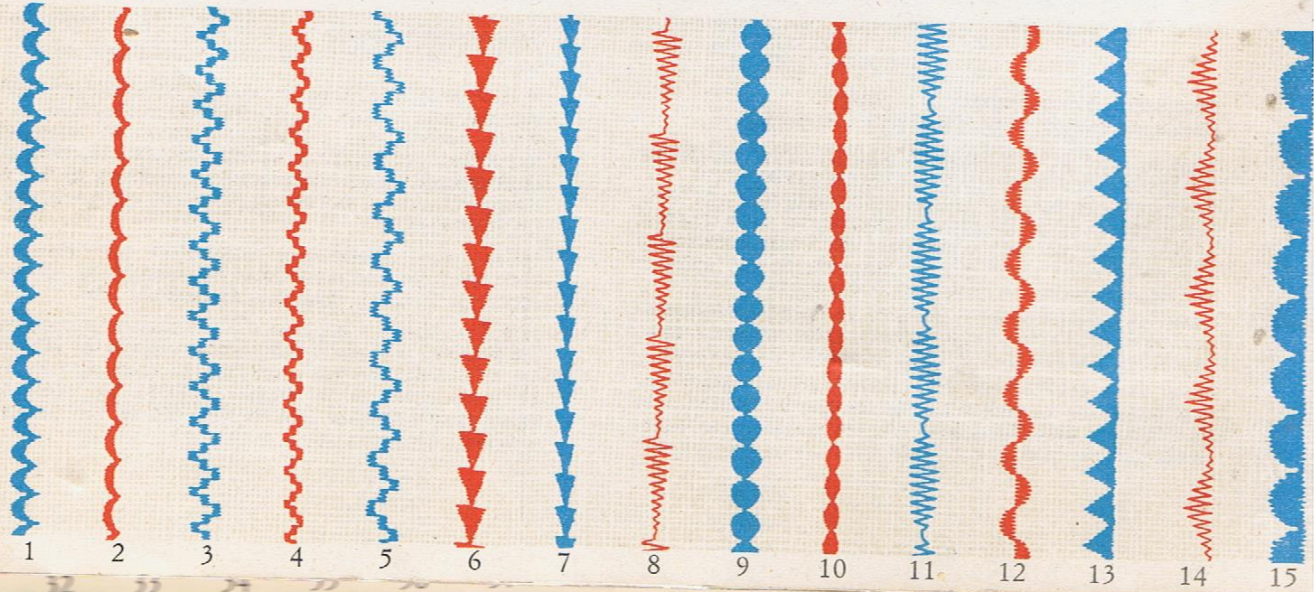





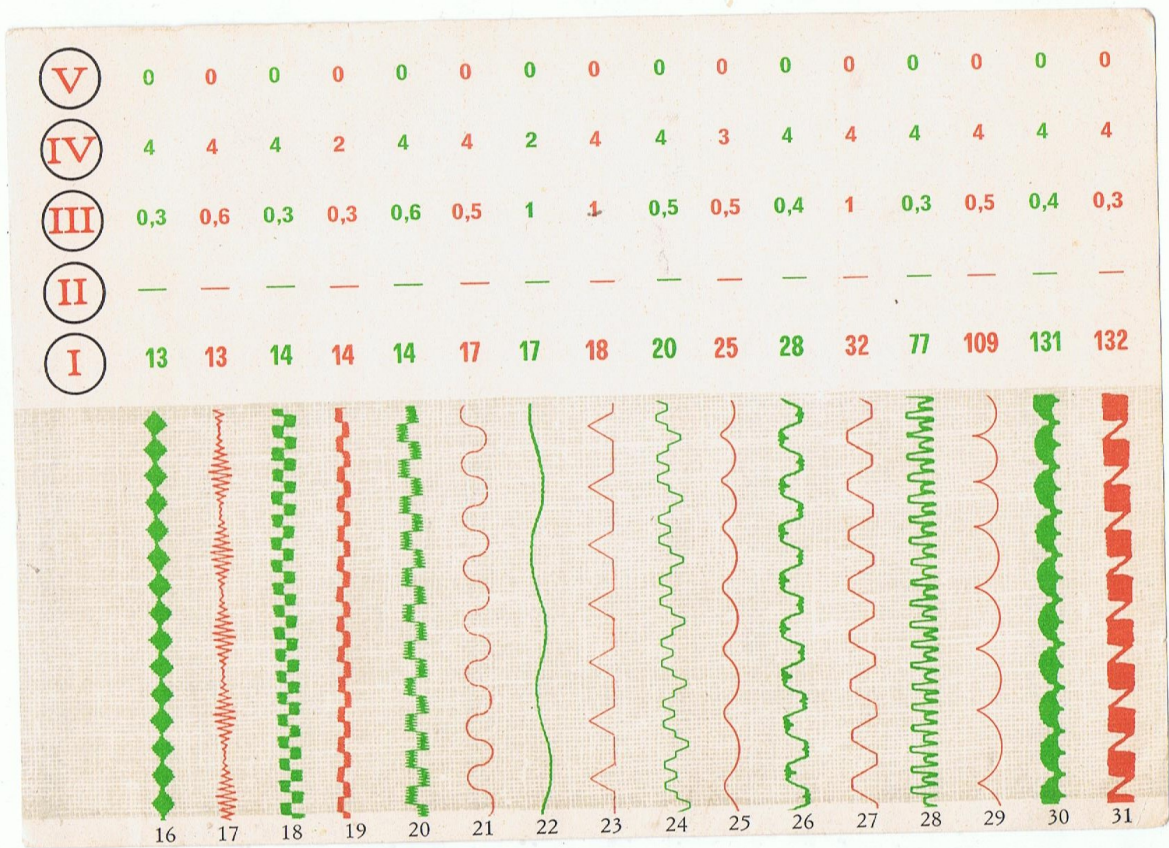





0	0	0	0	0	0	0	0	0	0	0	0	0	0	0	0
4	2	4	2	4	4	2,5	4	4	2	4	4	4	4	4	4
0,3	0,3	0,3	0,3	0,4	0,3	0,3	0,6	0,3	0,3	0,6	0,3	0,3	0,6	0,3	
—	—	—	—	—	—	—	—	—	—	—	—	—	—	—	—
1	1	2	2	2	3	3	3	9	9	9	10	11	11	12	12



1 2 3 4 5 6 7 8 9 10 11 12 13 14 15











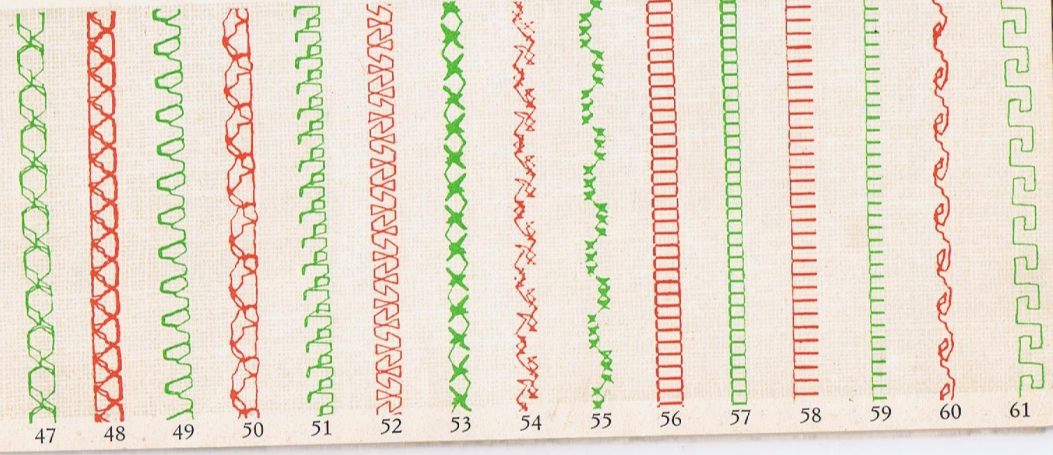









<b>V</b>	13	22	8	16	20	21	16	9	11	8	10	10	15	15	8
<b>IV</b>	4	4	4	4	4	4	4	4	4	4	4	4	4	4	4
<b>III</b>	4	4	0,7	1	1	1	1	1,3	1,3	1	4	1,5	0,5	2	1,7
<b>II</b>	8 A	4 A	24 A	24 A	24 A	20 A	20 A	21 E	21 A	21 A	28 A	28 A	28 A	28 A	27 A
<b>I</b>	2 A	5 A	5 A	5 A	5 D	5 D	5 D	5 D	5 D	5 A	5 A	5 A	5 A	5 A	5 D
															
	32	33	34	35	36	37	38	39	40	41	42	43	44	45	46

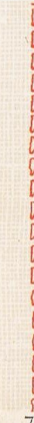

V	23	25	5	16	23	23	10	12	27	25	25	25	25	18	25
IV	4	4	4	4	4	4	4	4	4	4	2	4	2	2	4
III	4	4	0,6	4	4	4	4	4	4	4	4	4	4	4	4
II	26 A	26 A	25 A	32 F	6 A	6 A	7 A	32 A	43 B	16 A	16 A	19 A	19 A	29 A	20 A
I	5 A	5 D	5 D	5 F	7 B	8 E	10 A	14 A	14 A	15 A	15 A	18 A	18 A	20 A	21 A



<b>V</b>	22	23	20	17	22	23	14	23	23	21	15	21	17	27	24
<b>IV</b>	4	4	4	4	4	4	4	4	4	4	4	4	4	4	4
<b>III</b>	4	4	4	0,6	4	4	4	4	4	4	1	4	0,8	1	4
<b>II</b>	20 A	20 A	20 A	29 A	20 A	20 A	20 A	20 A	20 A	20 A	24 A	24 A	24 A	24 A	24 A
<b>I</b>	21 B	21 A	21 H	21 C	25 B	25 C	25 D	25 E	25 F	25 B	25 A	25 B	25 E	25 F	25 A
															
	62	63	64	65	66	67	68	69	70	71	72	73	74	75	76



V	10	16	21	22	14	17	9	23	23	6	18	19	10	13	18
IV	4	4	4	4	4	4	4	4	4	4	4	4	4	4	4
III	0,7	4	4	4	1,5	4	1	4	4	1	0,7	1	0,8	1	1
II	26 A	31 A	20 A	20 A	21 A	21 A	21 A	24 E	24 A	24 A	24 A	25 A	25 A	25 E	25 E
I	25 H	26 B	27 A	27 G	27 C	27 E	27 G	27 C	27 D	27 F	27 H	27 A	27 A	27 B	27 C

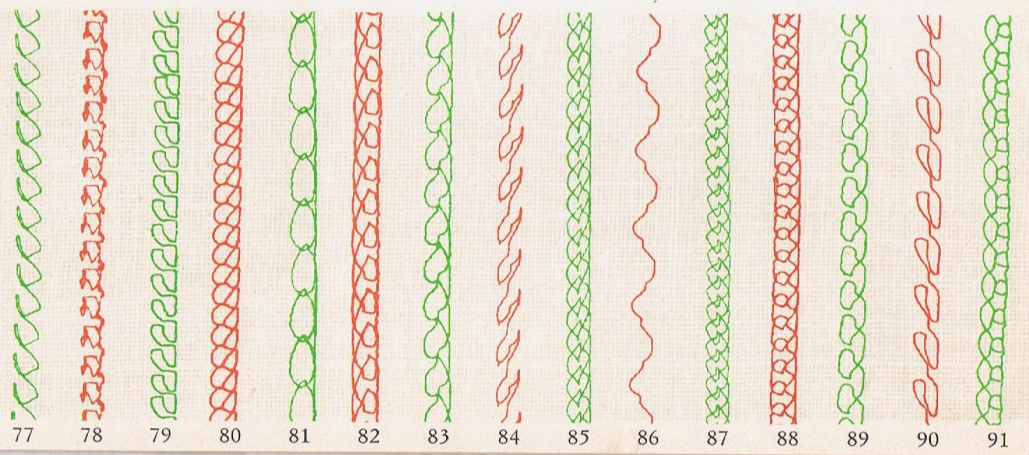

(V)	23	18	22	24	20	20	20	22	22	10	21	24	18	22	2
(I) (IV)	4	4	4	4	4	4	4	4	2	4	4	4	4	4	4
(I) (III)	4	1,4	1	4	4	4	4	4	4	0,6	4	4	4	4	1,
(I) (II)	25 A	25 E	25 E	26 A	26 A	26 A	26 A	26 A	26 A	26 A	26 A	26 A	26 A	26 A	26
(I)	27 E	27 F	27 G	27 B	27 C	27 H	27 A	27 A	27 A	27 A	27 B	27 B	27 C	27 C	27

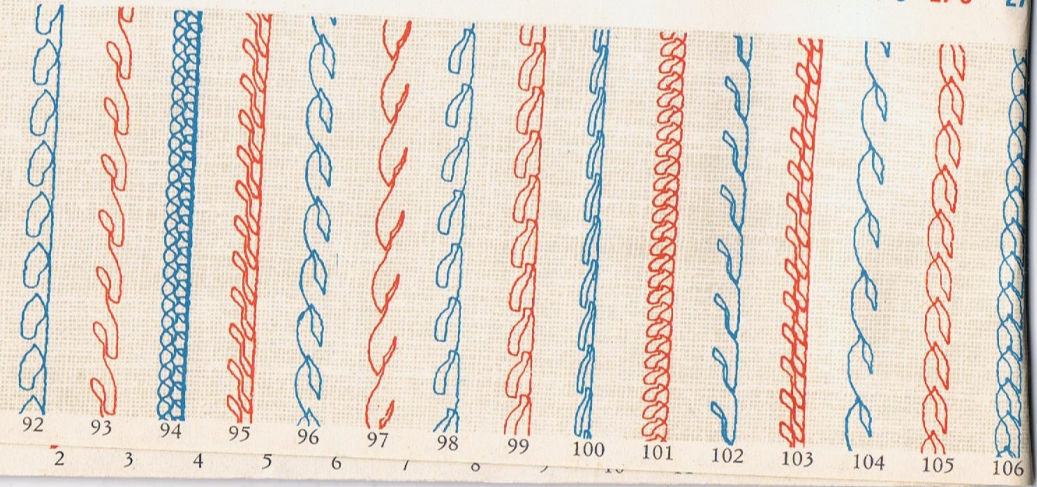

92 93 94 95 96 97 98 99 100 101 102 103 104 105 106



V	15	7	5	8	12	20	21	22	23	12	14	13	18	14	15
IV	4	4	4	4	4	4	4	4	4	4	4	4	4	4	4
III	4	1	1	1	1,5	4	1	4	0,5	4	4	4	4	4	4
II	28 A	28 A	28 A	28 A	28 A	29 A	29 A	29 A	29 A	32 A	32 A	32 A	7 A	8 A	8 A
I	27 C	27 D	27 D	27 E	27 G	27 A	27 B	27 C	27 H	27 A	27 B	27 A	28 A	28 B	28 E

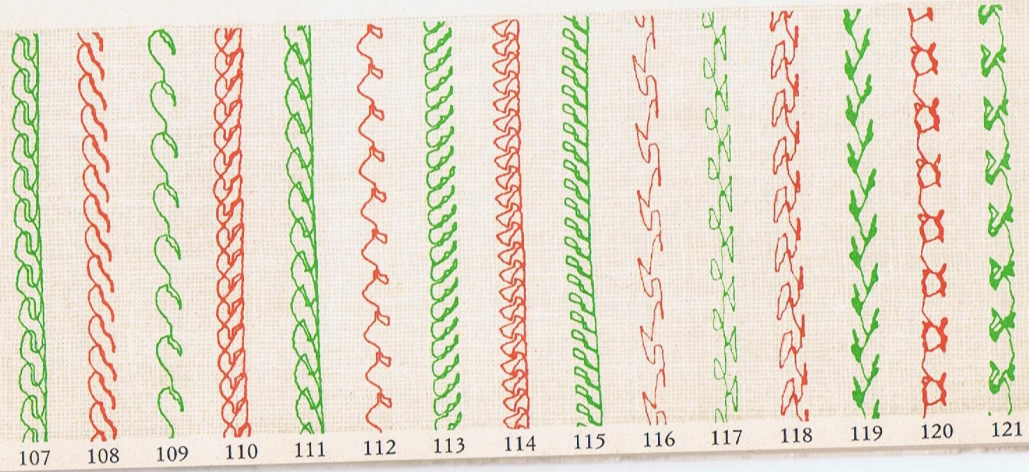

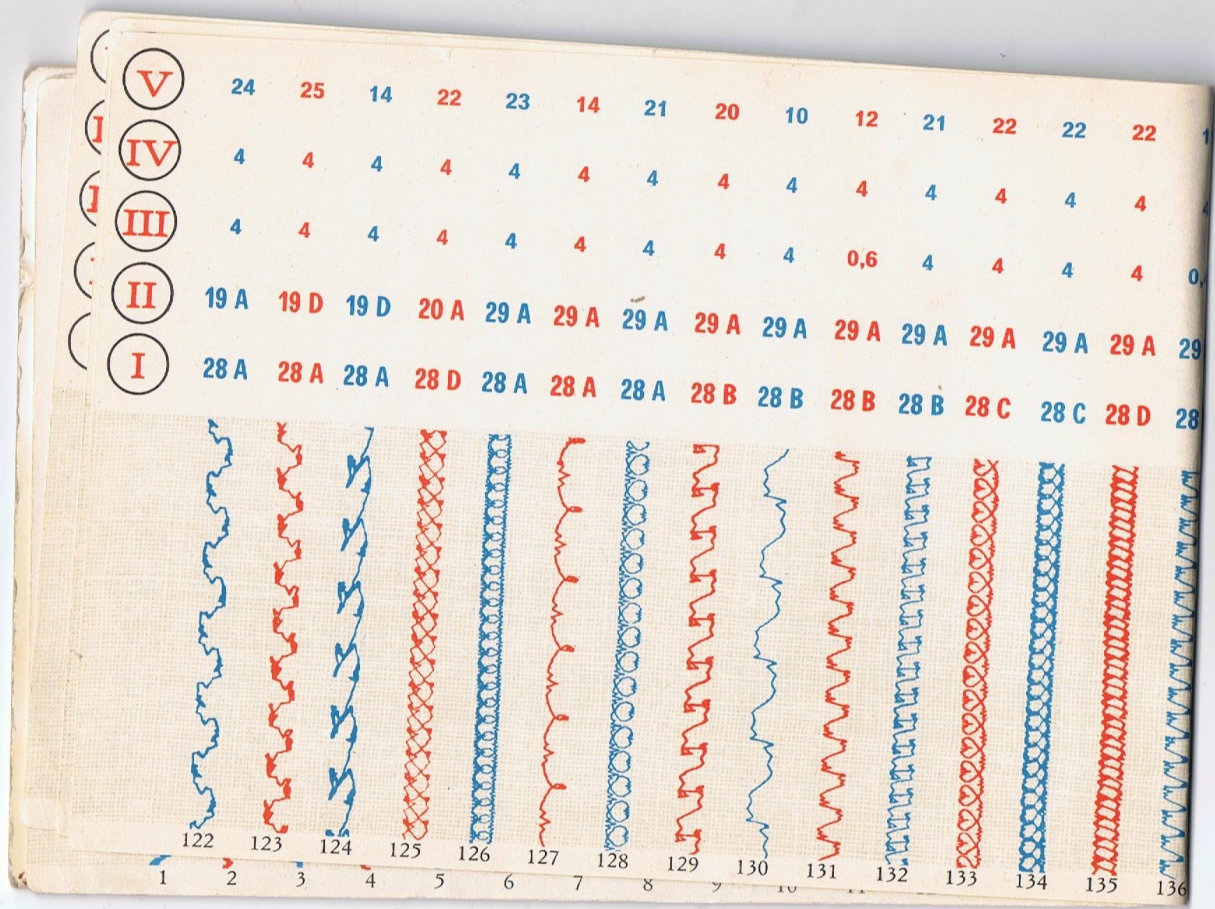



V	17	22	17	17	20	18	18	7	10	22	22	20	16	12	11
IV	4	4	4	4	4	4	2,5	1	4	4	2,5	4	4	4	4
III	4	4	4	0,5	4	4	1	4	0,5	4	4	4	4	4	4
II	29 A	29 A	29 A	29 A	29 A	29 A	29 A	29 A	29 A	29 A	29 A	29 A	30 A	30 A	30 A
I	28 F	28 G	28 H	28 H	28 A	28 A	28 A	28 A	28 A	28 A	28 A	28 A	28 C	28 B	28 E

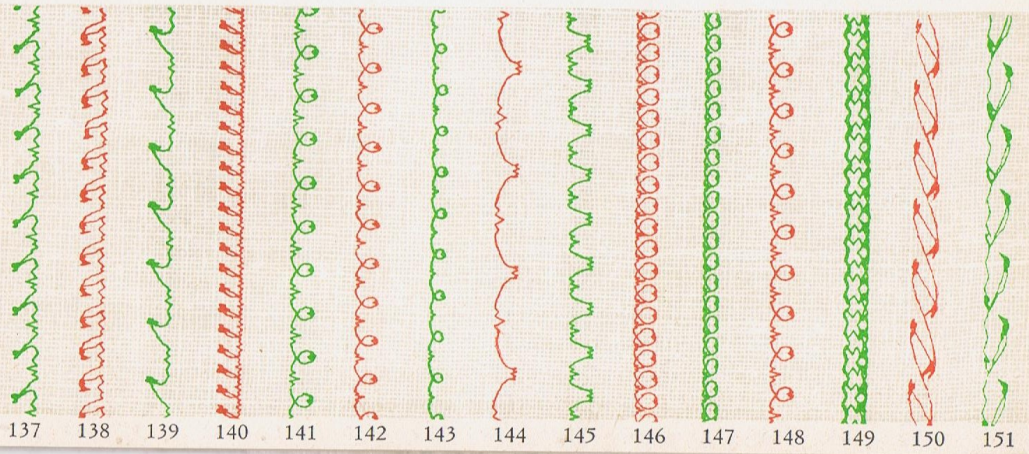

V	14	9	15	25	25	26	13	24	18	23	12	23	24	23	2
IV	4	4	4	4	2	4	4	4	4	4	4	4	4	4	4
III	4	4	4	4	4	4	4	4	4	4	4	4	4	4	4
II	30 A	30 A	32 E	31 A	31 A	6 A	7 A	6 A	25 F	4 C	28 G	4 B	43 A	43 A	43
I	28 H	28 A	28 A	30 A	30 A	32 A	32 A	32 A	32 A	32 D	32 E	32 G	44 A	44 E	44

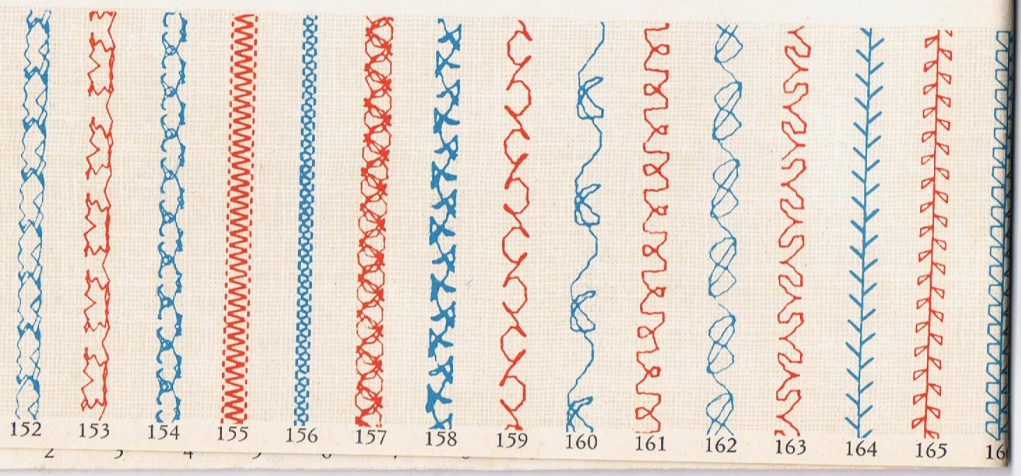

152 153 154 155 156 157 158 159 160 161 162 163 164 165 166



V	23	24	23	22	23	18	25	21	23	21	21
IV	4	4	4	4	4	4	4	0	4	0	3
III	4	4	4	4	4	4	4	4	4	4	4
II	43 A	43 A	43 A	43 A	71 A	8 A	90	90	71 A	150	150
I	45 A	45 B	45 F	45 G	62 A	74 A	90	—	93 A	—	—



167



168



169



170



171



172



173

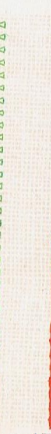

174





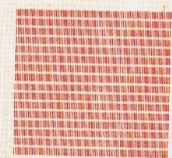







175



176

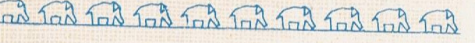

177

	<b>I</b>	<b>II</b>	<b>III</b>	<b>IV</b>	<b>V</b>
208 	46 A	47 A	4	4	25
209 	48 A	49 A	4	4	25
210 	62 A	63 A	4	4	23
211 	68 A	69 A	4	4	22
212 	70 A	71 A	4	4	23
213 	72 A	73 A	4	4	23
214 	74 A	75 A	4	4	23
215 	81 A	82 A	4	4	23
216 	83	84	4	4	20-25
217 	85	86	4	4	20-25



	I	II	III	IV	V
218 	91 A	92 A	4	4	24
219 	93 A	94 A	4	4	24
220 	95	96	4	4	20-25
221 	97	98	4	4	20-25
222 	99	100	4	4	20-25
223 	107	108	4	4	20-25
224 	112	113	4	4	20-25
225 	115	116	4	4	20-25
226 	117	118	4	4	20-25
227 	119	120	4	4	20-25
228 	121	122	4	4	20-25
229 	125	126	4	4	20-25